

# Telex Operating Instructions



**RadioCom™**

**BTR-800, TR-800, TR-825**

**Professional  
Wireless  
Intercom System**

**TELEX®**



## Thank you for choosing RadioCom

---

Telex Communications would like to take this opportunity to thank you for choosing the RadioCom™ BTR-800 Professional Wireless Intercom System. Many of the features in this product are the result of years of development work with many of the features developed from customer feedback. We hope that your experience with this product is a pleasant one and hope to provide you with a continuing line of RadioCom™ products well into the future. In order to get the most out of your new wireless intercom system, please take a few moments to look through this booklet before using the product for the first time.

-Telex Communications, Inc.



# Table of Contents

<b>Introduction</b> .....	1-1
General Description .....	1-1
System Features .....	1-1
BTR-800 Block Diagram .....	1-2
<b>BTR-800 Base Station</b> .....	2-1
Controls and Connections - Front Panel .....	2-1
Controls and Connections - Rear Panel .....	2-2
BTR-800 Specifications .....	2-3
<b>TR-800 Beltpack</b> .....	3-1
Controls and Connections - Top Panel .....	3-1
Controls and Connections - Rear Panel .....	3-2
TR-800 Specifications .....	3-3
<b>TR-825 Beltpack</b> .....	4-1
Controls and Connections - Top Panel .....	4-1
Controls and Connections - Rear Panel .....	4-2
TR-825 Specifications .....	4-3
<b>Initial Equipment Set-Up</b> .....	5-1
Unpacking .....	5-1
Antenna Connections .....	5-2
Antenna Polarization .....	5-2
Distance Between Antennas .....	5-2
Antenna Placement .....	5-2
Improving Reception/Increasing Range .....	5-4
<b>Base Station Set-Up</b> .....	5-5
Location .....	5-5
Power Connection .....	5-5
Transmit Switches .....	5-5
Internal Transmit Switches .....	5-6
Intercom Switch .....	5-6
Intercom Interface .....	5-6
Dual Listen Functionality .....	5-8
Auxiliary Input/Output .....	5-9
Internal Auxiliary Input Routing Switch .....	5-9
Stage Announce /Relay Contacts .....	5-10
Base Station Link .....	5-11
<b>Beltpack Set-Up</b> .....	5-12
Battery Installation .....	5-12
Antenna Connection .....	5-13
Transmit Mode .....	5-13
Headset Connection .....	5-13
<b>Pre-Walk-Thru Checklist</b> .....	6-1
<b>System Operation</b> .....	7-1
Frequency Plan Overview .....	7-1
Factory-Defined Group .....	7-1
User-Programmable Groups .....	7-1
System Quick Start .....	7-1
<b>Base Station Operation</b> .....	7-2
Power .....	7-2
Local Headset .....	7-2
Portable Station Connect .....	7-2
Intercom A and B .....	7-2
Auxiliary .....	7-2
Display Contrast .....	7-3
<b>BTR-800 Menu Structure</b> .....	7-4
Main Screen Flowchart .....	7-4
Power-Up Screen .....	7-5
Operating Screen .....	7-5
Beltpack Activity Code Definitions .....	7-5
Group/Channel Select .....	7-6
Group/Frequency Select .....	7-7
Frequency Edit .....	7-8
Clear Scan .....	7-9
<b>Special Key Sequences</b> .....	7-10
Lockout .....	7-10
Copy .....	7-10
1st Use Default .....	7-10
Factory Default .....	7-10

## Table of Contents (continued)

<b>TR-800 Beltpack Operation</b> .....	7-11
Power/Local Headset Volume .....	7-11
Battery Check .....	7-11
Talk Button .....	7-11
Microphone Gain .....	7-11
Channel Select Button .....	7-11
Stage Announce (SA) .....	7-11
Wireless Talk Around (WTA) .....	7-11
<b>TR-800 Beltpack Menu Structure</b> .....	7-12
Power-Up Screens .....	7-13
Group/Channel Screen .....	7-14
Transmit Screen .....	7-15
Receive 1 Screen .....	7-16
Receive 2 Screen .....	7-17
ClearScan™ .....	7-18
Feature Enable/Disable Menus .....	7-19
Stage Announce Enable/Disable .....	7-19
Wireless Talk Around Enable/Disable .....	7-19
Audio Channel A or B Enable/Disable .....	7-20
Talk Button Latch on/Latch off .....	7-20
<b>Special Key Sequences</b> .....	7-21
Lockout .....	7-21
1st Use Default .....	7-21
Factory Default .....	7-21
<b>TR-825 Beltpack Menu Structure</b> .....	7-22
Power-Up Screens .....	7-23
Group/Channel Screen .....	7-24
Transmit Screen .....	7-25
Receive 1 Screen .....	7-26
Receive 2 Screen .....	7-27
Audio Output .....	7-28
ClearScan™ .....	7-29
Feature Enable/Disable Menus .....	7-30
Stage Announce Enable/Disable .....	7-30
Wireless Talk Around .....	7-31
Audio Channel A Options .....	7-32
Audio Channel B Options .....	7-33
<b>Special Key Sequences</b> .....	7-34
Lockout .....	7-34
1st Use Default .....	7-34
Factory Default .....	7-34
<b>System Walk-Thru</b> .....	8-1
<b>Trouble Shooting</b> .....	9-1
<b>Tech Tips</b> .....	10-1
Frequency Interaction .....	10-1
Microphone Gain Adjustment .....	10-1
<b>Battery Information</b> .....	11-1
<b>Intercom System Specifications</b> .....	12-1
<b>Accessories and Replacement Parts</b> .....	13-1
<b>Customer Service Information</b> .....	14-1
<b>Software License</b> .....	15-1
<b>FCC Information</b> .....	16-1
<b>Limited Warranty</b> .....	17-1

### General Description

The Telex RadioCom™ BTR-800 UHF Synthesized Wireless intercom systems offer the ultimate in reliable, high-performance, high-fidelity full-duplex communications.

The BTR-800 system includes the BTR-800 frequency agile base station, working with up to four TR-800 or TR-825 frequency agile beltacks. The BTR-800 base station provides full-duplex communications with the beltacks.

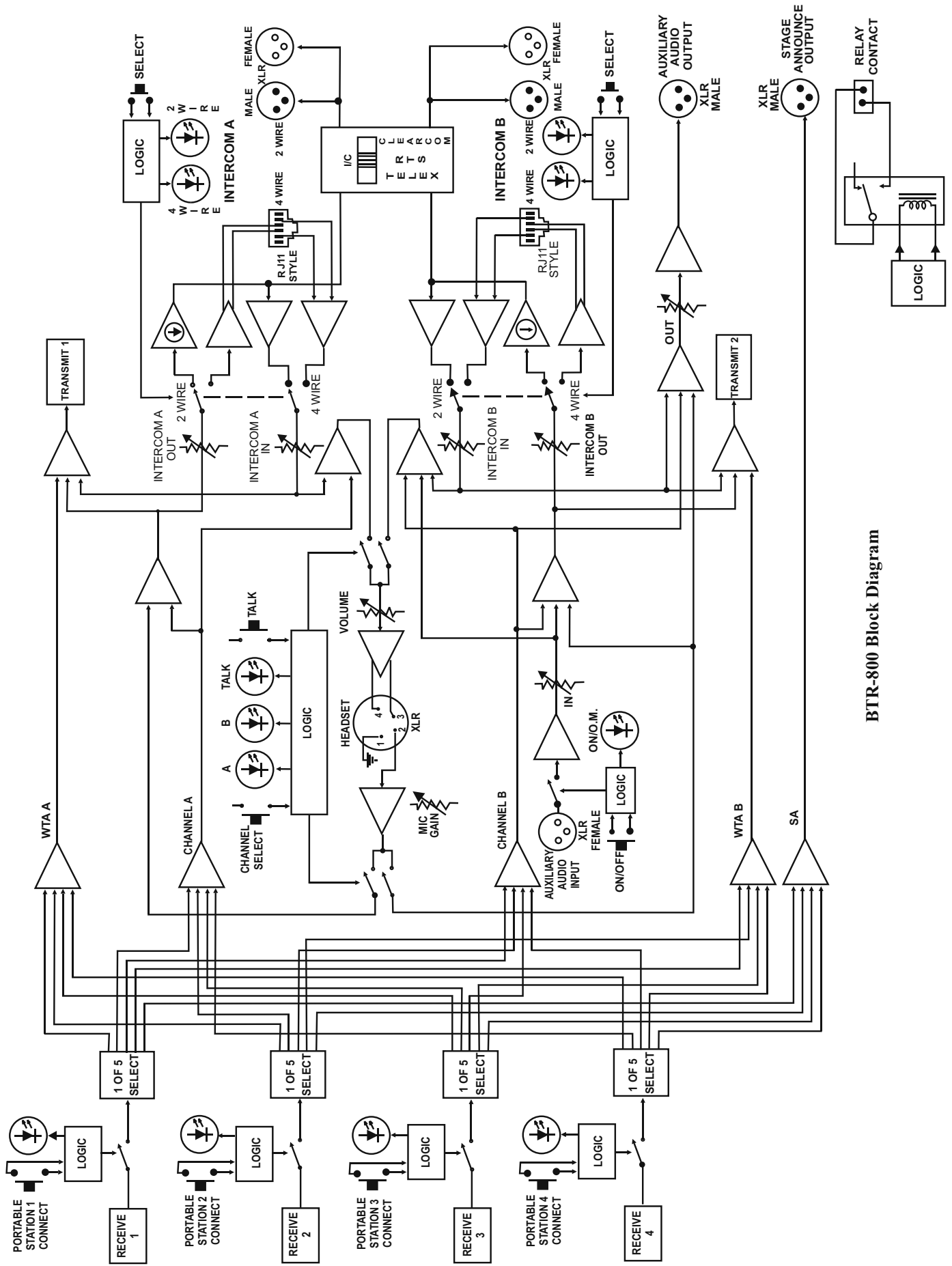
The BTR system incorporates two audio channel operation, permitting the beltack operator to choose between two separate audio channels of communications, with the base station tracking the beltack selection. This allows the user the flexibility to create a party-line and a private line within the same beltack.

The BTR-800 system is perfectly suited for stand-alone operation and also can interface with Audiocom® (Telex), RTS® TW, Clear-Com®, as well as RTS Matrix systems and other 4-wire communications systems. In addition to the external intercom systems interfaces listed above, the system provides connections for auxiliary balanced audio input and output, as well as wireless talk-around (WTA) and stage announce (SA) features.

The RadioCom™ BTR series has been designed for reliable, efficient operation. Operating in the 470 to 740 MHz range, the units operate reliably at line-of-sight distances of 1,000 feet. With available antenna systems, from Telex, the effective operating range can be extended. The high-efficiency beltacks provide up to 12 hours of uninterrupted operation using standard alkaline batteries.

### System Features

- Frequency-agile base station and beltacks. No external computer/device required to select frequencies.
- Backlit base-station LCD allows the user to easily monitor the beltack's status as well as change base-station frequencies.
- ClearScan™ function on base station and beltack to automatically find the best channels on which to operate.
- Full-duplex (simultaneous talk and listen) operation.
- Compatible with Audiocom® (Telex), RTS TW, Matrix, Clear-Com®, and other wired intercom types.
- Two channels of intercom audio.
- WTA (Wireless Talk Around) beltack control. This feature allows beltacks to talk to each other, but their audio is lifted from any wired system connected to the base station.
- SA (Stage Announce) beltack control. Allows the user to direct their audio to a jack on the back of the base for P.A. systems or other external audio systems.
- Relay contact closure on the base when the SA button is pressed.
- TR-825 features two audio channel binaural operation in either stereo or mono mode.
- Beltack units contained in a weather and shock resistant die cast magnesium case.
- Convenient IEC power connector on the base station so the unit can plug directly to outlets. No in-line or wall plug power supply.
- Base station comes with rack ears for easy rack mounting.



BTR-800 Block Diagram



# Section 2

## BTR-800 Base Station

### Controls and Connections - Front Panel

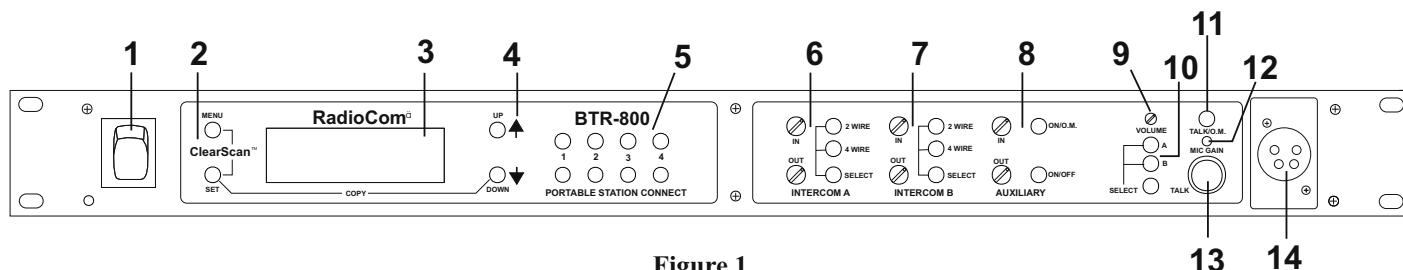
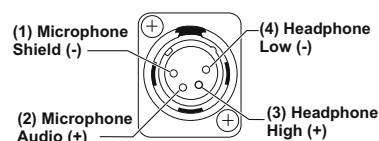


Figure 1  
BTR-800 - Front Panel

1. **Power switch.**
2. **[Menu] and [Set] buttons** – Used to select menus and set options on the LCD.
3. **Backlit Graphics LCD (Liquid Crystal Display).**
4. **[Up] and [Down] buttons** – Used to select base station options on the LCD.
5. **Portable Station Connect** – Buttons used to enable or disable the respective receiver’s audio. GREEN LED = Audio enabled, LED OFF = Audio disabled.
6. **Intercom A Controls** - Wired intercom A interface controls. Audio input and output level controls. 2-wire or 4-wire select button with green LED indicator lights. Selected LED will change to RED if the input levels are too high.
7. **Intercom B Controls** - Wired intercom B interface controls. Audio input and output level controls. 2-wire or 4-wire select button with green LED indicator lights. Selected LED will change to RED if the input levels are too high.
8. **Auxiliary Controls** - Wired auxiliary interface controls. Audio input and output level controls. GREEN LED = Aux. input enabled. LED will change to RED if the input levels are too high.
9. **Headset Volume** – Controls the volume to the headset connected to #14.
10. **Headset Intercom Select** – Controls the intercom to which the local headset is connected. Each press of the button changes the connection; channel A, channel B, both.
11. **Talk/Overmod Light** – LED is green when talk button #13 is active. A normal mic gain setting will cause the LED to flash red on the loudest speech levels. If the gain is too high, the LED will be red at normal speech volumes.
12. **Microphone Gain** – Adjusts the headset’s microphone gain. Adjusts so that the overmod light #11 flashes from green to red on loudest speech.
13. **Talk Button** – Press to enable the audio path from the local headset. LED #11 will turn green when enabled. A quick press and release latches button on. If the talk function is latched on, pressing the talk button again will turn it off.
14. **Local Headset Connector** – Male XLR connector for Telex units, Female XLR connector for RTS units. A dynamic or electret headset microphone is automatically detected.

#### Telex Units



#### RTS Units

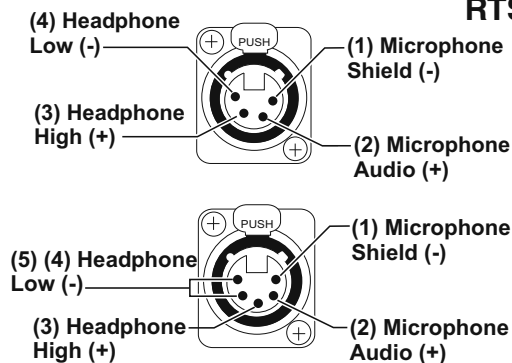
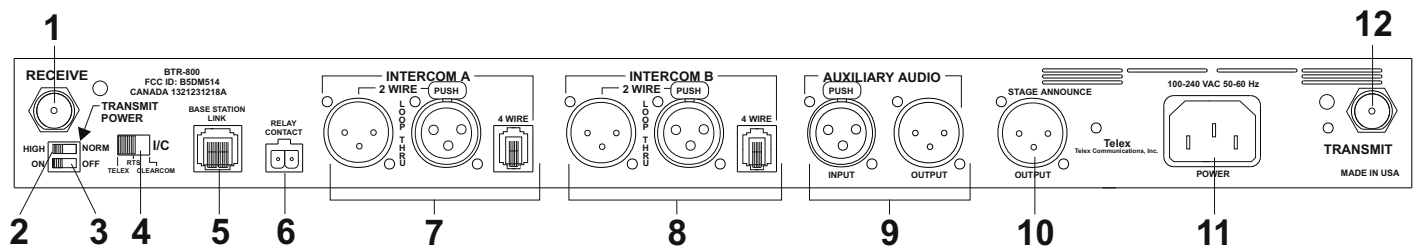


Figure 2  
Local Headset Wiring

## Controls and Connections - Rear Panel



**Figure 3**  
**BTR-800 - Rear Panel**

1. **Receive Antenna** - Female “TNC” Connector. Color band on antenna must match color dot on base station.
2. **Transmit Power Switch** – HIGH = Transmitters at full power. NORMAL = Transmitters 10dB below full power.
3. **Transmit ON/OFF Switch** – Turns the transmitters on or off.
4. **I/C Select Switch** – Set to the appropriate 2-wire intercom type being interfaced to the unit. Set to either Telex, RTS or Clear-Com®.
5. **Base Station Link Jack** – When two base stations are connected through this jack, it allows wireless talk around (WTA) from the beltpacks to be routed from the system with it’s transmitters off to the system with it’s transmitters on.
6. **Relay Contact** – A dry contact closure which is activated when a beltpack user presses the stage announce (SA) button. Normally Open (NO). One amp at 24V maximum.
7. **Intercom A** – Interface to wired intercom system A.
  - 2-Wire** – Male and female 3-pin XLR connectors wired in parallel. The connectors are switched to the appropriate intercom configuration via the I/C Select Switch.
  - 4-Wire** – An RJ-11 type jack compatible with “Matrix” type intercom systems.
8. **Intercom B** – Interface to wired intercom system B.
  - 2-Wire** – Male and female 3-pin XLR connectors wired in parallel. The connectors are switched to the appropriate intercom configuration via the I/C Select Switch.
  - 4-Wire** – An RJ-11 type jack compatible with “Matrix” type intercom systems.
9. **Auxiliary Input/Output** – One 3-pin female XLR input connector and one 3-pin male XLR output connector.
10. **Stage Announce Output** – Passes the audio from any of the base station’s beltpacks that have selected stage announce (SA).
11. **Power** – IEC receptacle. Accepts 100 – 240 VAC, 50 – 60 Hz.
12. **Transmit Antenna** - Female “TNC” Connector. Color band on antenna must match color dot on base station.

# BTR-800

## Specifications

### *Overall*

RF Frequency Range	470 - 608 MHz, 614 - 740 MHz in 18 MHz TX and RX bands
Power Requirements	100-240 VAC, 50-60 Hz, IEC receptacle
Temperature Range	-4° F to 130° F (-20° C to 55° C)
Dimensions	19.00" W x 1.72" H x 14.00" D (48.3 cm x 4.4 cm x 35.6 cm)
Weight	7 lbs 2 oz (3.24 kg)
TX Antenna	1/2 Wave (supplied), TNC Male Connector
RX Antenna	1/2 Wave (supplied), TNC Male Connector
FCC ID:	B5DM514
Frequency Response	300Hz-8kHz
Four Wire Input	Level Adjustable (2 Vrms typical)
Four Wire Output	Level Adjustable (2 Vrms typical)
Telex Intercom	Input/Output Level Adjustable (1 Vrms typical), Line impedance 300Ω
RTS Intercom	Input/Output Level Adjustable (0.775 Vrms typical), Line Impedance 200Ω
Clear-Com® Intercom	Input/Output Level Adjustable (1 Vrms typical), Line Impedance 200Ω
Auxiliary Input	Adjustable (2 Vrms typical)
Auxiliary Output	Adjustable (2 Vrms typical into 600Ω)
Stage Announce Output	Internally Adjustable (2 Vrms typical at rated deviation into 600Ω)
Stage Announce Relay	Dry contact, rated at 1 Amp, 24V Max
Microphone input sensitivity	9mV
Local Headset Output	40mW output into 600Ω (1% Distortion)

### *Transmitter*

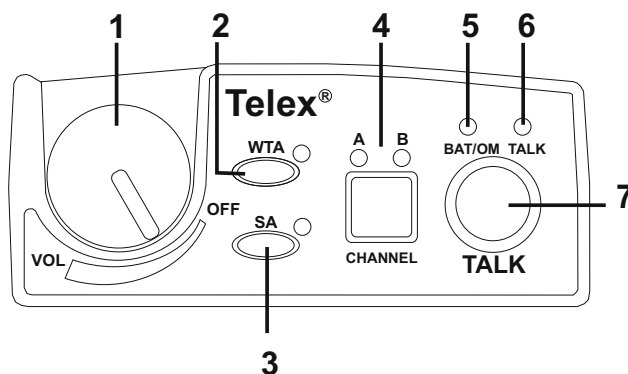
Type	Two Synthesized Transmitters, 712 channels each
Transmit Power (each transmitter)	100mW Max. (High), 10 mW (Normal)
Modulation Type	FM
Deviation	40 kHz
RF Frequency Stability	0.005%
Modulation Limiter	Peak-Responding Compressor
Radiated Harmonics & Spurious	Exceeds FCC specifications

### *Receiver*

Type	Dual Conversion Superheterodyne, four Independent Synthesized IFs, FM, 712 channels each
RF Sensitivity	<0.8 μV for 12 dB SINAD
Squelch Threshold	20 dB SINAD
IF Selectivity	3 dB at 230 kHz
Image Rejection	70 dB or better
Squelch Quieting	90 dB
RF Frequency Stability	0.005%
Distortion	<1% at full deviation



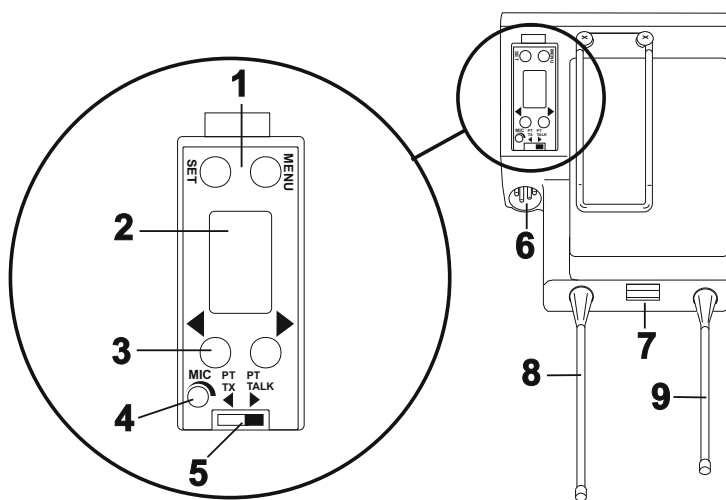
### Controls and Connections - Top Panel



**Figure 4**  
**TR-800 Top Panel**

1. **On/Off & Volume Control** – Turns the beltpack power on and controls headset volume.
2. **Wireless Talk Around (WTA)** – When pressed, the user’s audio is disconnected from the wired intercom, auxiliary input/output and the base station’s local headset. Other beltpack users, on that audio channel, can hear the user as normal. The button activates the nearby red LED as well as the “TALK” LED, #6, when pressed.
3. **Stage Announce (SA)** –When pressed, the user’s audio is routed to the stage announce connector on the back of the base station. The user also loses their sidetone as an indication that stage announce is activated. The other wireless beltpacks and wired users do not hear the user’s audio. The button is non-latching and activates the nearby red LED as well as the “TALK” LED, #6, when pressed.
4. **Audio Channel Select Button** – Allows user to select either audio channel A or B.
5. **Bat/Overmod Light (BAT/OM)** – Light will flash once when unit is turned on if the battery is good. If the light stays on, battery is low. If the light does not flash, battery is dead. A normal microphone gain setting will cause the LED to flash at the beginning of most words at normal speech levels. If the gain is too high, the LED will be red during the complete word at normal speech levels.
6. **Talk Light** – LED is on when the talk button, SA or WTA is active.
7. **Talk button** – Press to enable the audio path from the local headset microphone. The “TALK” LED, #6, will turn red when enabled. A quick press and release latches the talk function, unless latching has been disabled. Holding the button for over ½ a second will cause the audio path to be enabled only for as long as the button is held. If the talk function is latched on, pressing the talk button again will turn it off.

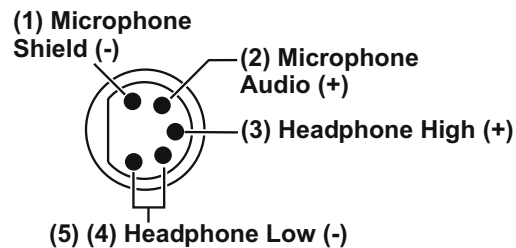
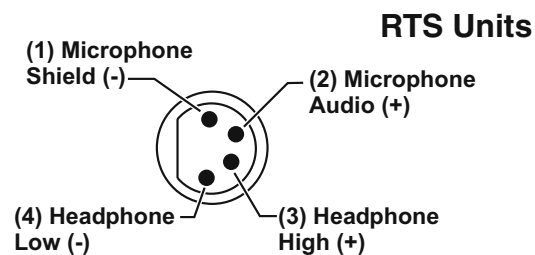
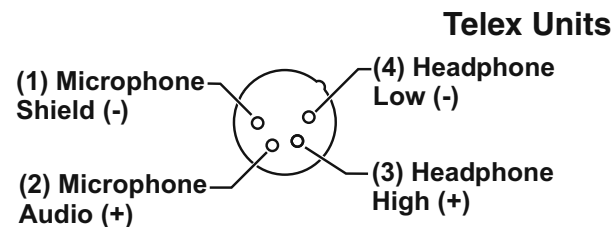
## Controls and Connections - Rear Panel



**Figure 5**  
TR-800 Rear Panel/Connector/Antennas

1. **[MENU] and [SET] buttons** – Used to select menus and set options on the LCD.
2. **LCD (Liquid Crystal Display)**
3. **[UP] and [DOWN] buttons** – Used to select beltpack options on the LCD.
4. **Microphone Gain** – Adjusts the headset’s microphone gain. Adjust so that the BAT/OM LED will flash at the beginning of most words at normal speech levels
5. **Push-to-Talk/Push-to-Transmit Switch** –
  - Push-to-Talk (PT TALK)** – The transmitter is always on. No audio sent unless the talk switch, WTA or SA button pressed. Recommended position.
  - Push-to-Transmit (PT TX)** - The transmitter and audio path are off except when the talk switch, WTA or SA button is pressed.

6. **Headset Connector** – Male XLR connector for Telex units, Female XLR connector for RTS units. A dynamic or electret headset microphone is automatically detected by the beltpack and a bias voltage supplied if needed.



**Figure 6**  
Headset Jack Wiring

7. **Battery Latch** – Press down to enable the battery pack to be released. While the latch is held down, slide the battery pack about 1/8 inch back, toward the latch, until it stops. Then lift out.
8. **Receive Antenna** – Screw type ¼-wave replaceable antenna. The color dot on the screw end of the antenna must match color dot on antenna receptacle.
9. **Transmit Antenna** – Screw type ¼-wave replaceable antenna. Color dot on the screw end of the antenna must match color dot on antenna receptacle.

## **TR-800 Specifications**

RF Frequency Range . . . . .	470 - 608 MHz, 614 - 740 MHz in 18 MHz TX and RX bands
Power Requirements . . . . .	6 "AA" Cells Alkaline (NiMH optional)
Current Draw . . . . .	140 mA (Push-to-Talk, Talk On)
Temperature Range . . . . .	-4° F to 130° F (-20° C to 55° C)
Dimensions . . . . .	3.75"W x 5.05"H x 1.65" D (9.5 cm x 12.8 cm x 4.2 cm)
Weight . . . . .	16 oz (454g) with alkaline batteries
TX Antenna . . . . .	1/4 Wave (supplied), Screw type, Replaceable
RX Antenna . . . . .	1/4 Wave (supplied), Screw type, Replaceable
FCC ID: . . . . .	B5DM518 (TX 470-608 MHz), B5DM515 (TX 614-746 MHz)
Frequency Response . . . . .	300Hz-8kHz
Microphone input sensitivity . . . . .	7 mV
Local Headset Output . . . . .	40 mW output into 600Ω (1% distortion)

### ***Transmitter***

Type . . . . .	Synthesized, 712 channels
Transmit Power . . . . .	50 mW Max. (auto-power reduction)
Modulation Type . . . . .	FM
Deviation . . . . .	40 kHz
RF Frequency Stability . . . . .	0.005%
Modulation Limiter . . . . .	Peak-Responding Compressor
Radiated Harmonics & Spurious . . . . .	Exceeds FCC specifications

### ***Receiver***

Type . . . . .	Dual Conversion Superheterodyne, Synthesized, FM, 712 channels
RF Sensitivity . . . . .	<0.7 μV for 12 dB SINAD
Squelch Threshold . . . . .	20 dB SINAD (About 1.0 μV)
IF Selectivity . . . . .	3 dB at 230 kHz
Image Rejection . . . . .	70 dB or better
Squelch Quieting . . . . .	90 dB
RF Frequency Stability . . . . .	0.005%
Distortion . . . . .	<1% at full deviation





### Controls and Connections - Top Panel

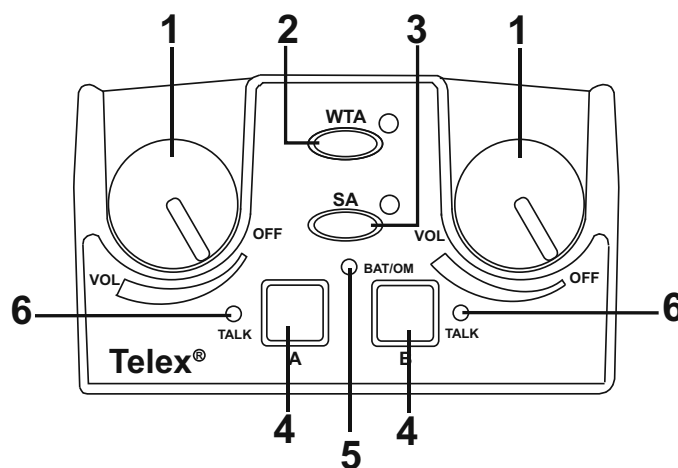


Figure 7  
TR-825 Top Panel

- 1. On/Off and Volume Control** - Turns beltpack power on and controls headset volume for Intercom Channels "A" and "B". Either knob, "A" or "B", turns the beltpack on. Both knobs must be off to turn the beltpack off. If only one knob is off, then only that Intercom Channel, "A" or "B" is off for both transmit and receive audio.
- 2. Wireless Talk Around (WTA)** - When pressed, the user's audio is disconnected from the wired intercom, auxiliary input/output and the base station's local headset. Other beltpack users, on that audio channel, can hear the user as normal. The default setting is software selectable, as to which Intercom Channel, "A", "B", "A + B", or currently selected channel, is activated along with the "WTA" button. The "WTA" button activates the nearby red LED as well as the software selected Intercom Channel "TALK" LED if not already active.
- 3. Stage Announce (SA)** - When pressed, the user's audio is routed to the stage announce connector on the back of the base station. The user also loses their sidetone as an indication that stage announce is activated. The other wireless beltpacks and wired users do not hear the user's audio. The button is non-latching and activates the nearby red LED.
- 4. Talk Button** - Press to enable the audio path to either Intercom Channel "A" or "B" or "A + B", from the local headset microphone. The associated "TALK" LED, #6, will turn red when enabled. A quick press and release latches the talk function, unless latching has been disabled. Holding the button for over ½ second, will cause the audio path to be enabled only for as long as the button is held. If the talk function is latched on, pressing the talk button again will turn it off.
- 5. Low Battery/Overmodulation (BAT/OM) Light** - Light will flash once when unit is turned on if the battery is good. If the light stays on, battery is low. If the light does not flash, battery is dead. A normal microphone gain setting will cause the LED to flash at the beginning of most words at normal speech levels. If the gain is too high, the LED will be red during the complete word at normal speech levels.
- 6. Talk Light** - Will turn red when enabled by associated "TALK" or "WTA" button.

# Controls and Connections - Rear Panel

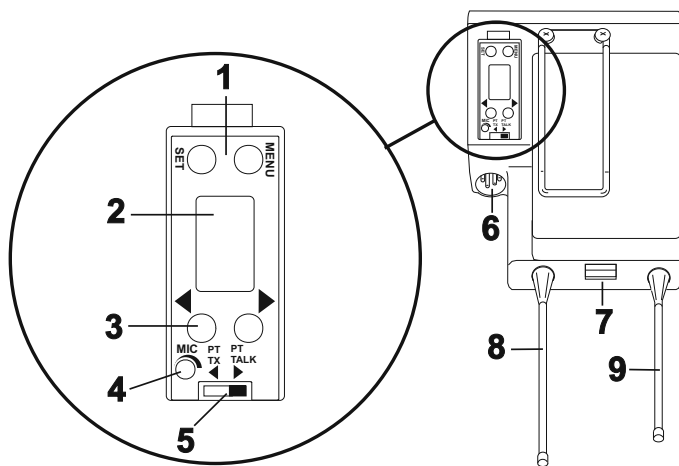


Figure 8

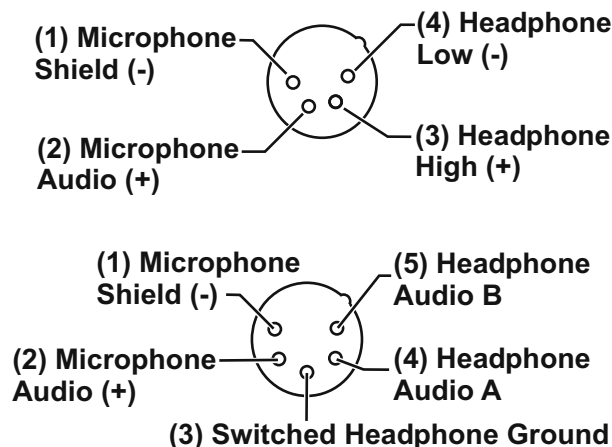
TR-825 Rear Panel/Connector/Antennas

1. **[MENU] and [SET] buttons** – Used to select menus and set options on the LCD.
2. **LCD (Liquid Crystal Display)**
3. **[UP] and [DOWN] buttons** – Used to select beltback options on the LCD.
4. **Microphone Gain** – Adjusts the headset’s microphone gain. Adjust so that the BAT/OM LED will flash at the beginning of most words at normal speech levels
5. **Push-to-Talk/Push-to-Transmit Switch** –  
**Push-to-Talk (PT TALK)** – The transmitter is always on. No audio sent unless the talk switch, WTA or SA button pressed. Recommended position.  
  
**Push-to-Transmit (PT TX)** - The transmitter and audio path are off except when the talk switch, WTA or SA button is pressed.

6. **Headset Connector** – Male XLR connector for Telex units, Female XLR connector for RTS units. A dynamic or electret headset microphone is automatically detected by the beltback and a bias voltage supplied if needed. Four pin Telex/RTS units are monaural. Five pin Telex/RTS units have a software set-up which grounds or opens pin 3.

Menu Set	PIN 3	RESULT ON 5-PIN DUAL HEADPHONE
[ Ab SEP ]	GND	A in one side, B in other side
[ Ab Add ]	OPEN	A + B

## Telex Units



## RTS Units

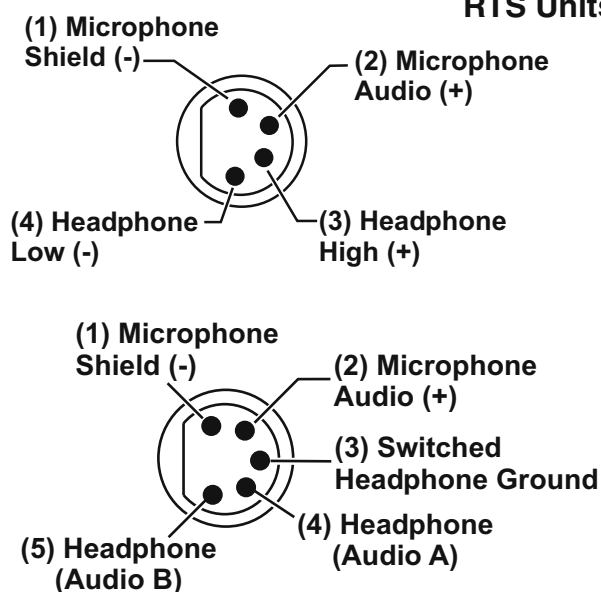


Figure 9  
Headset Jack Wiring

Single sided 5-pin headsets will only receive A or B, depending on how headphone is wired. These headsets must have the beltback set for [Ab SEP]

7. **Battery Latch** – Press down to enable the battery pack to be released. While the latch is held down, slide the battery pack about 1/8 inch back, toward the latch, until it stops. Then lift out.
8. **Receive Antenna** – Screw type ¼-wave replaceable antenna. The color dot on the screw end of the antenna must match color dot on antenna receptacle.
9. **Transmit Antenna** – Screw type ¼-wave replaceable antenna. The color dot on the screw end of the antenna must match color dot on antenna receptacle.

## **TR-825 Specifications**

RF Frequency Range . . . . .	470 - 608 MHz, 614 - 740 MHz in 18 MHz TX and RX bands
Power Requirements . . . . .	6 "AA" Cells Alkaline (NiMH optional)
Current Draw . . . . .	190 mA (Push-to-Talk, A and B Talk On)
Temperature Range . . . . .	-4° F to 130° F (-20° C to 55° C)
Dimensions . . . . .	3.75" W x 5.35" H x 2.02" D (9.5 cm x 13.5 cm x 5.1 cm)
Weight . . . . .	21 oz (595g) with alkaline batteries
TX Antenna . . . . .	1/4 Wave (supplied), Screw type, Replaceable
RX Antenna . . . . .	1/4 Wave (supplied), Screw type, Replaceable
FCC ID: . . . . .	B5DM517
Frequency Response . . . . .	300Hz-8kHz
Microphone input sensitivity . . . . .	7 mV
Local Headset Output . . . . .	40 mW output into 600Ω (1% distortion)

### ***Transmitter***

Type . . . . .	Synthesized, 712 channels
Transmit Power . . . . .	50 mW Max. (auto-power reduction)
Modulation Type . . . . .	FM
Deviation . . . . .	40 kHz
RF Frequency Stability . . . . .	0.005%
Modulation Limiter . . . . .	Peak-Responding Compressor
Radiated Harmonics & Spurious . . . . .	Exceeds FCC specifications

### ***Receiver***

Type . . . . .	Two, Dual Conversion Superheterodyne Receivers, Synthesized, FM, 712 channels
RF Sensitivity . . . . .	<0.8 μV for 12 dB SINAD
Squelch Threshold . . . . .	20 dB SINAD (About 1.0 μV)
IF Selectivity . . . . .	3 dB at 230 kHz
Image Rejection . . . . .	70 dB or better
Squelch Quieting . . . . .	90 dB
RF Frequency Stability . . . . .	0.005%
Distortion . . . . .	<1% at full deviation



# Section 5

## Initial Equipment Set-Up

---

### Unpacking

Unpack your RadioCom™ System. Below are the items that should come with your base station and each belt pack.

Contact the shipper or your dealer immediately if anything is damaged or missing. Fill out the registration card and return it to Telex to register the unit.

#### **BTR-800**

Quantity	Description
1	BTR-800 Base Station
1	Operating Instructions
1	Power Cord
2	Antennas (one Transmit and one Receive)
1	Warranty Card
1	Screwdriver
1	2 terminal plug (for SA Relay)
1	Warning Card
4	Rubber feet

#### **TR-800, TR-825**

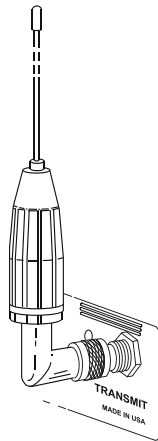
Quantity	Description
1	TR-8XX with Antennas
1	Battery pack
1	Instruction Sheet
1	Screwdriver
1	Warranty Card

## Antenna Connection

The base station is supplied with two (2) antennas. One 1/2-wave antenna for Transmit and one 1/2-wave for Receive. The antennas have TNC male connectors.

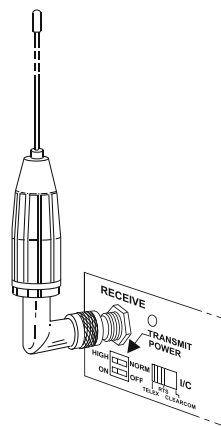
The frequency range of the antennas should match the receiver and transmitter of the base station. Match the color code on the antenna with the color code on the base station.

Attach the transmit 1/2-wave antenna to the antenna input receptacle labeled "Transmit" on the right side of the rear panel. The antenna should be vertically aligned.



**Figure 10**  
**Attaching Transmit 1/2-Wave Antenna**

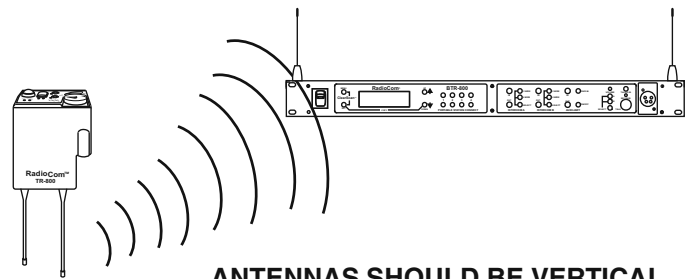
Attach the receive 1/2-wave antenna to the antenna input receptacle labeled "Receive" on the left side of the rear panel. The antenna should be vertically aligned.



**Figure 11**  
**Attaching Receive 1/2-Wave Antenna**

## Antenna Polarization

The Telex Wireless Intercom System is "Vertically Polarized". This means both the transmitting and receiving antennas should operate in the vertical position.



**Figure 12**  
**Vertically Polarized Antennas**

## Distance between Antennas

The distance between the base station's receive and transmit antennas is not adjustable when the antennas are connected directly on the back of the unit.

The antennas can be remoted for better signal path. A Telex coax assembly with remote antennas may be required. See "Accessory" section for ordering information.

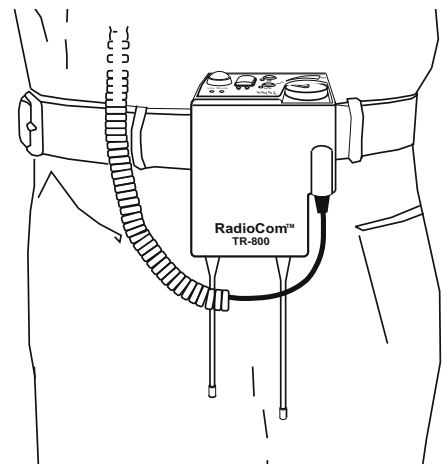
**NOTE:** If your base station is to be located in a shielded rack mount enclosure or other poor RF location, you must remote the 1/2-wave antennas with coax assemblies. See "Accessories and Replacement Parts" section for remote mounting hardware.

## Antenna Placement

Proper antenna placement probably has the most effect on your TELEX Wireless Intercom System's overall performance. The following suggestions will result in optimum performance.

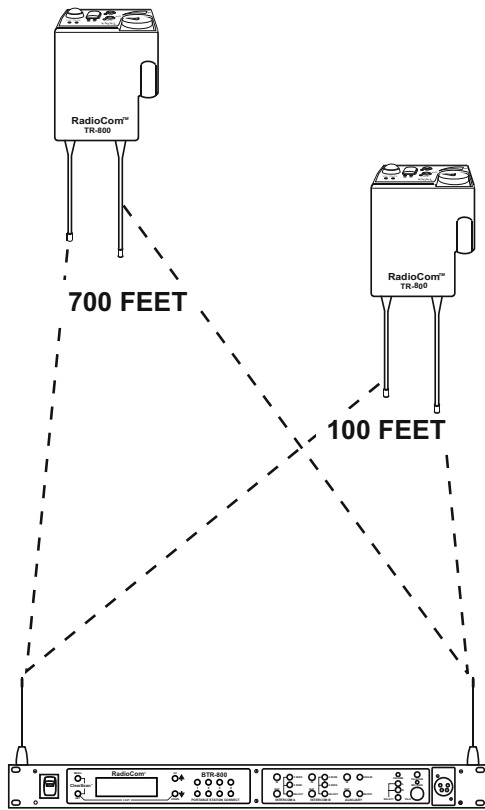
Proper placement of the beltpack can be critical. The antennas should be in the open. Bending the antennas up and placing the beltpack in a pocket, etc., will reduce system distance.

It is suggested that the unit be worn on the belt or pocket with both antenna's vertical for best operating range and performance.

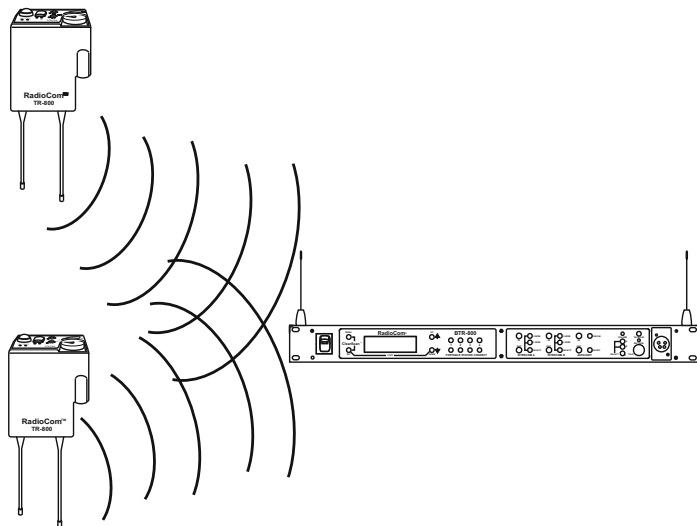


**Figure 13**  
**Proper Dressing of the Antennas**

Keep the distance between the base station and the beltacks as short as possible. The greater the distance, the weaker the signal. Make sure the “signal paths” between the base station and beltacks are unobstructed. You should be able to visibly locate the base station antennas at all times for best performance.

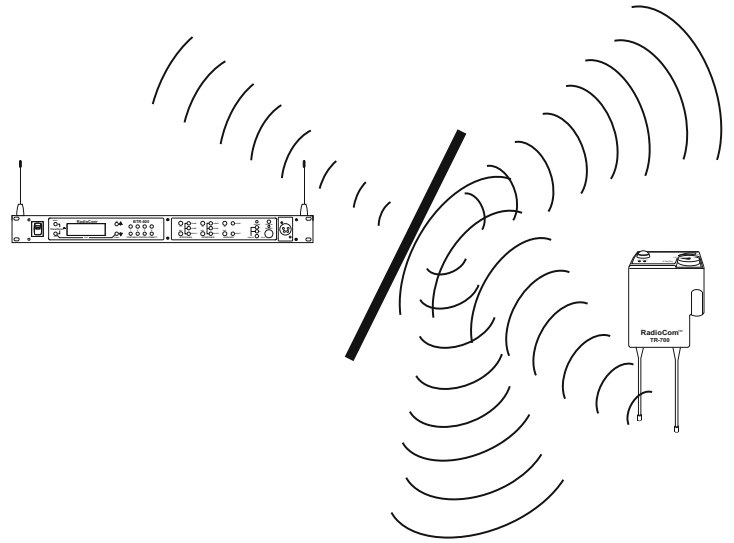


**Figure 14**  
Distance Between base station and beltack



**Figure 15**  
Keeping Site Clear to Antenna

Attempting to operate the wireless intercom system through or around walls, ceilings, metal objects, etc. will reduce system range and performance.



**Figure 16**  
Operating System Near Obstructions

**DO NOT** - mount the base station 1/2-wave antennas on, or next to metal, such as beams, walls with metal studs, equipment racks, etc. This also applies to the antennas when assembled directly to the Base Station. This will “detune” the antennas which can result in noise or loss of RF signal at the Base Station, see Figure 17.

2. Placing the BTR on top of a shelf or equipment rack unobstructed without remoting the antennas is OK.

1. Placing BTRs in a shelf or equipment rack and using remote antennas is OK.

3. Placing BTRs in a shelf or equipment rack with the antennas mounted on the back of the BTR or the side of the rack is **BAD**.

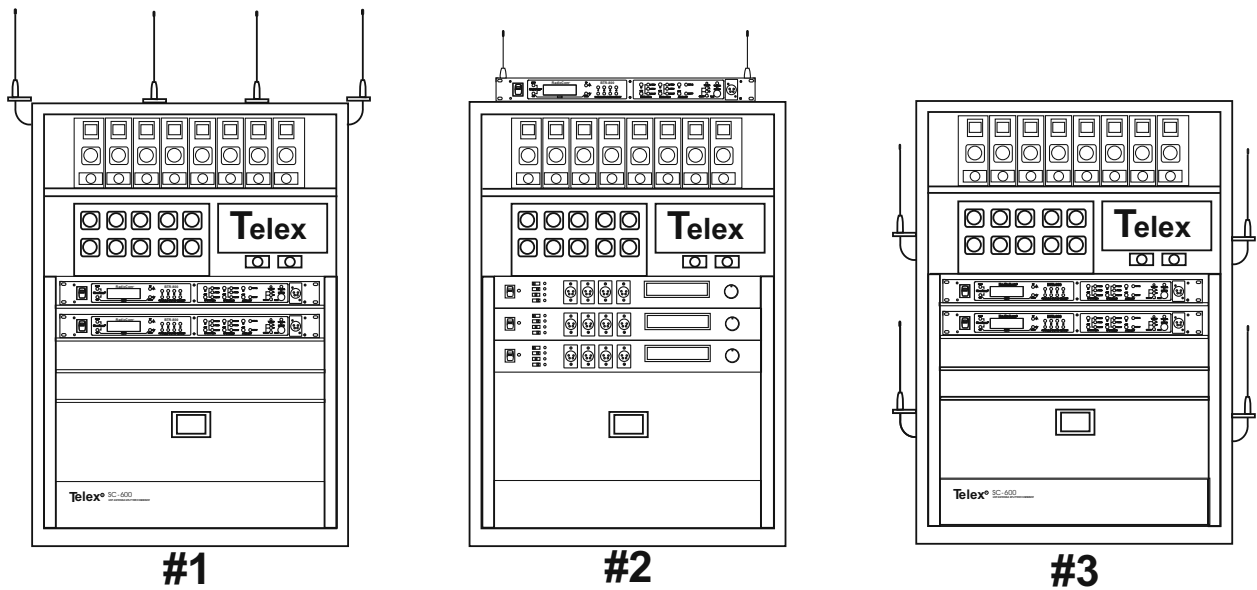


Figure 17  
Antenna Placement

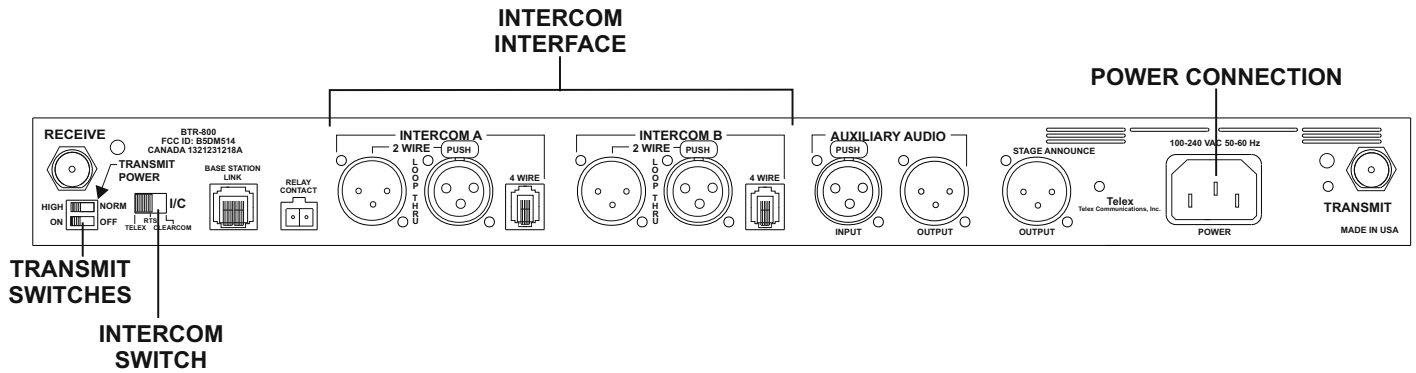
## Improving Reception and Increasing Range

Keeping the distance from the base station and beltback as short, and unobstructed as possible will produce the most reliable performance.

The base station is supplied with two antennas. This should provide satisfactory system performance in most applications. System range can be enhanced by remoting the 1/2-wave antennas. The 1/2 wave antennas are ground plane independent, so a ground plane is not required for good performance.



## Base Station Set-up



**Figure 18**  
**Base Station - Rear Panel**

### Location

Locate the base station with the front and rear of the unit accessible so that switches may be set and connections made. Place the transmit and receive antennas on the base station. Make sure the antenna's color band match the color dot near each antenna. See "Antenna Information" section for more information on choosing a proper operating location.

### Power Connection

Plug the supplied power cord into the unit. The base station has an IEC power receptacle that accepts 100 – 240 VAC, 50 – 60 Hz. The specific receptacle type is an IEC 60320/C14. The cord it accepts is an IEC 60320/C13. These cords are common and available through many retail hardware/electronic stores if the cord is lost.

### Transmit Switches

There are two switches located on the lower left side of the rear panel. The upper switch sets the transmit power levels to high or normal. The lower switch turns the transmitters on or off.

#### Transmit Power

Set the power level to normal if using the belt packs at close to medium distances (<200 feet, 161m, line-of-sight) from the base station. Set the power level to high if using the belt packs at a distance (>200 feet, 161m, line-of-sight) from the base station.

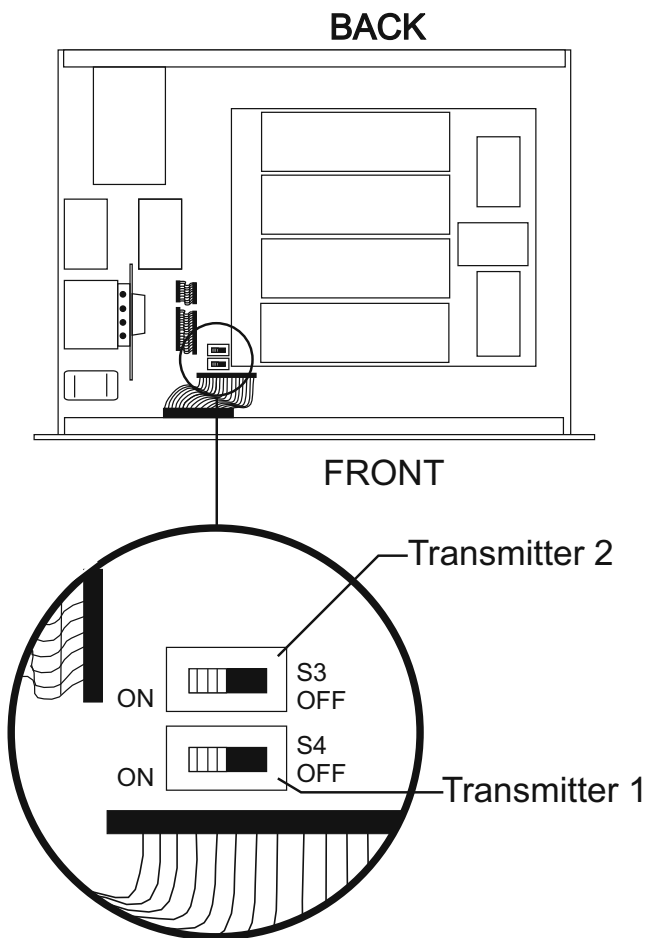
#### On/Off

Set the transmitter switch to on for normal use. In the off position both base station transmitters are disabled. Setting the switch to off will disable all the belt packs from hearing anyone else or even their own sidetone.

## Internal Transmit Switches

Internal to the BTR-800 are two transmit switches which enable a user to turn on or off the two transmitters individually. See Figure 19 for the location. The top cover of the base station must be removed for access. The switch closest to the front panel controls transmitter 1 (audio channel A). The switch behind that is transmitter 2 (audio channel B). The default switch position is to the left if you are facing the front of the base station. This is the "ON" position for the transmitters.

In the normal use of the BTR-800, there is no need to access these switches. They are used to test the transmitters individually at the factory.



**Figure 19**  
Internal Transmit Switches

## Intercom Switch

The RadioCom® wireless system can be interfaced to RTS, TW, Audiocom® (Telex), Clear-Com®, RTS matrix and other intercom (I/C) systems. Set the Intercom switch on the rear of the unit to the appropriate system and connect the system to the base station. The two intercom channels on the rear of the base station have loop-thru male and female XLR connections for two-wire systems and RJ-11 type jacks for four-wire systems.

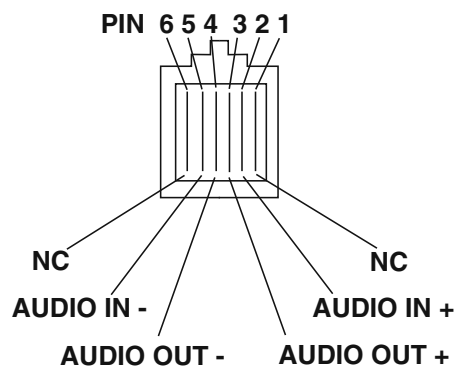
This switch only affects the two-wire intercom systems. The functions of the I/C XLRs change depending on the intercom selected. Please see Section 12 for pinout information of the different two-wire intercom systems.

## Intercom Interface

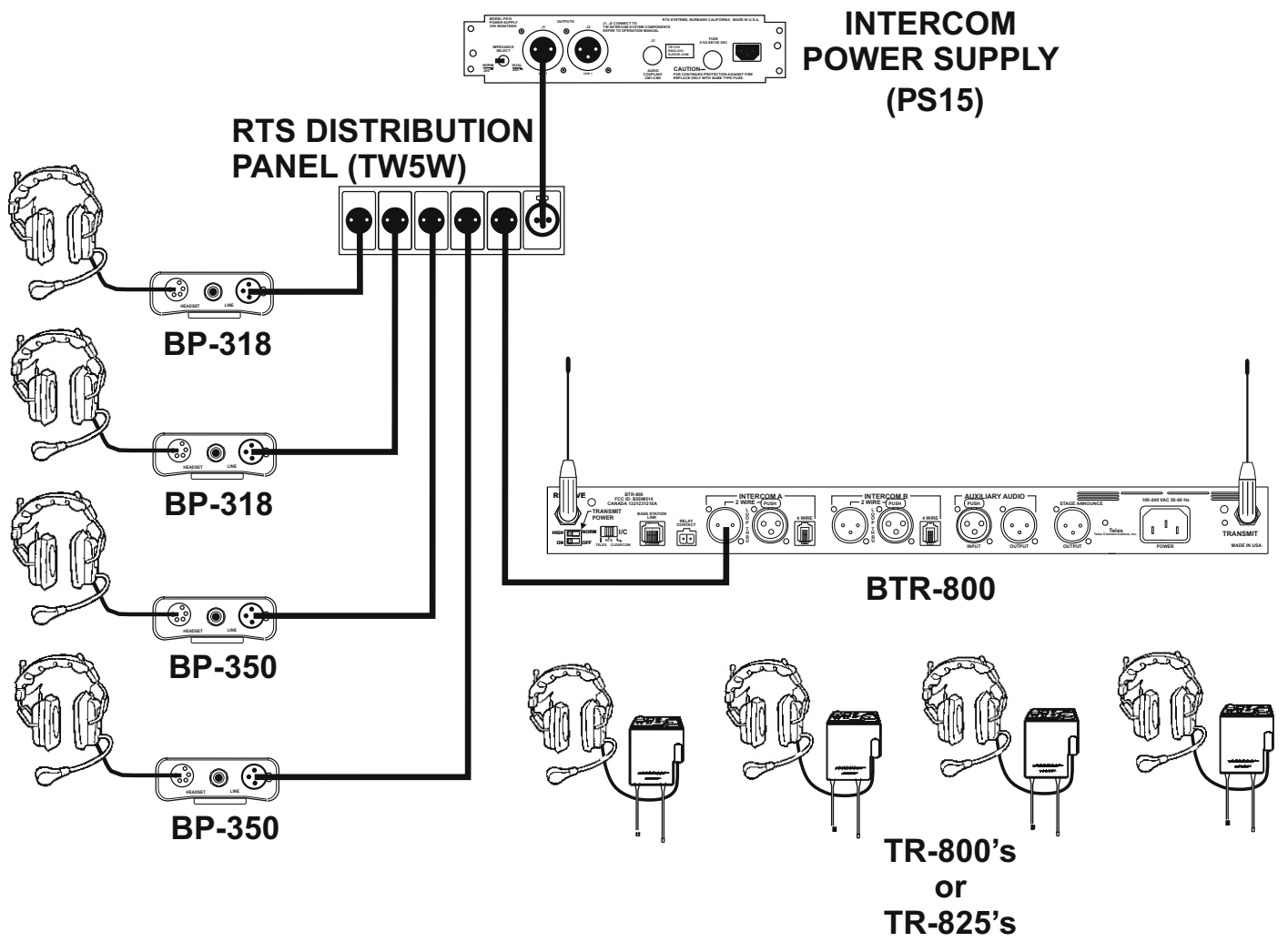
Telex (Audiocom®) and Clear-Com® intercom systems require one cable for intercom A and one cable for intercom B in order to interface two channels of intercom to the base station. This interfacing is done through the I/C A and B 3-pin XLR connectors on the rear of the unit.

RTS TW intercoms only need to connect one 3-pin cable to one of the four intercom XLR connectors since two channels of audio are carried on one cable. The intercom switch parallels the four XLR connectors when in RTS mode. RTS channel 1 is placed on intercom A and RTS channel 2 is placed on intercom B as long as the RTS TW input to the base station is wired as in Section 12.

Four-wire intercom systems require one cable for intercom A and one cable for intercom B in order to interface two channels of four-wire intercom to the base station. This interfacing is done through the I/C A and B RJ-11 type jacks on the rear of the unit. See Figure 20 for the pinout of the RJ-11 jacks.



**Figure 20**  
RJ-11 Type/ Four-wire Pinout



**Figure 21**  
**Example Interface to an RTS TW System**

## Dual Listen Functionality

The base stations's main audio board has the option of placing additional parts to enable dual listen. Dual listen allows the mixing of the intercom channels. The mixing will occur locally, within the base station, and is only heard on that base station's beltpacks. The user will have the ability to enable/disable the mix of I/C A into I/C B or vice versa. If you have TR-825 beltpacks, there is no need to install this base option. The level of the mix can be controlled at the TR-825 via the two volume controls.

They will also have the ability to control the level of the mix (-4 dB to -24 dB down from main channel). Removing two surface mount resistors and installing two SPDT switches and two potentiometer enables dual listen. The parts to be installed are shown in Table 1. The two resistors on the board to be removed are in Table 2.

Board Designator	Description and Function	Value	Manufacturers, Part No.
VR5, VR6	Potentiometers VR5 = Controls I/C A into I/C B Mix VR6 = Controls I/C B into I/C A Mix	20kΩ - 25kΩ	Bourns, 3309P-1-203 CTS, U262R253B Piher, PT10LV10-203A2020
S6, S7	Switches S6 = Enable/Disable I/C A into I/C B Mix S7 = Enable/Disable I/C B into I/C A Mix	SPDT	E-Switch, 500ASSP1M2RE E-Switch, EG1218 Alcoswitch, TSS11DGPC

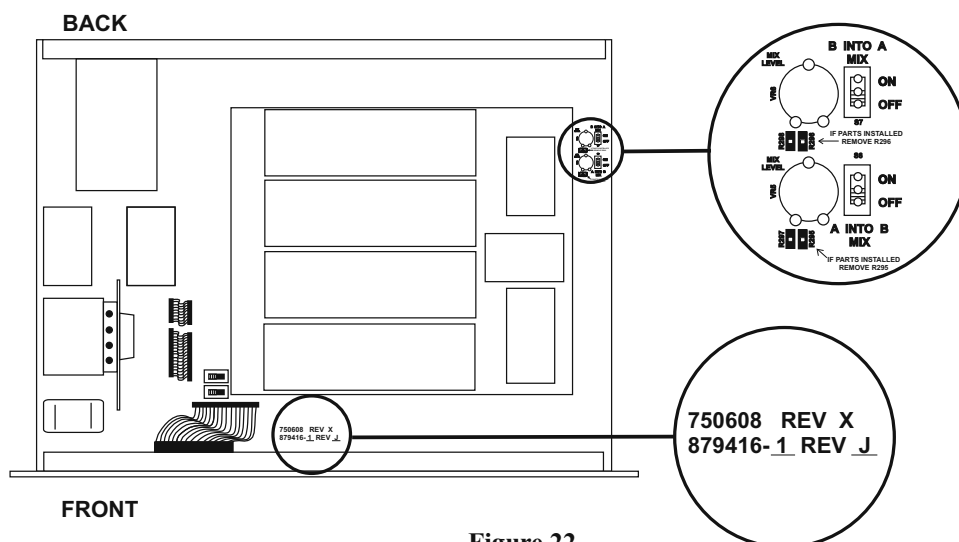
**Table 1**  
**Parts to be Installed by User to Enable Dual Listen**

Board Designator	Description and Function	Value
R295	Resistor, Default if mix components not installed	10k
R296	Resistor, Default if mix components not installed	10k

**Table 2**  
**Parts to be Removed by User to Enable Dual Listen**

The listed manufactures and part numbers in Table 1 are those that the audio board was laid out for and thus the hole pattern used. Several of these parts may be found at Digi-Key and other distributors. Trim the leads on the parts so they can not hit the metal case. Locations to place these components are provided on audio board part number 750608.

The audio board part number is located on the lower left hand side of the board if facing the front of the unit. The locations where the components can be installed are on the upper right hand side of the board. See Figure 22 for the locations. Board part number 750541 does not have locations to place components, however, modification documents may be obtained from Telex Communications for those who wish to modify older audio boards for dual listen.



**Figure 22**  
**Audio Board Part Number and Dual Listen Component Locations**

## Auxiliary Input/Output

The input and output 3-pin XLR auxiliary connections are for supplying additional balanced audio into and receiving balanced audio from the base station. **The output auxiliary connection only interfaces to intercom B.** However, there is an internal switch to control the routing of the input auxiliary audio. See the "Internal Auxiliary Input Routing Switch" section of this manual.

**The input and output auxiliary audio is global.** This means the input auxiliary audio is placed on the base local headset, beltpack(s), headsets, and **any wired intercom system interfaced to the base station.** The intercom channel(s) the input auxiliary audio is placed on depends on the position of the input routing switch.

The output auxiliary audio is also taken from the intercom B base local headset, beltpack(s), headsets, and **any wired intercom connected to the base station.** A modification document is available from Telex Communications for those who wish to modify the base station so that auxiliary input audio is heard only locally; base local headset and beltpack(s) headsets.

## Internal Auxiliary Input Routing Switch

This switch controls the routing of the input auxiliary audio. This switch has two positions. The "B" position places auxiliary input audio onto intercom B only (default from factory). The "A & B" position places auxiliary input audio onto intercom A and B. Please see Figure 23 for the location of this internal auxiliary input routing switch.

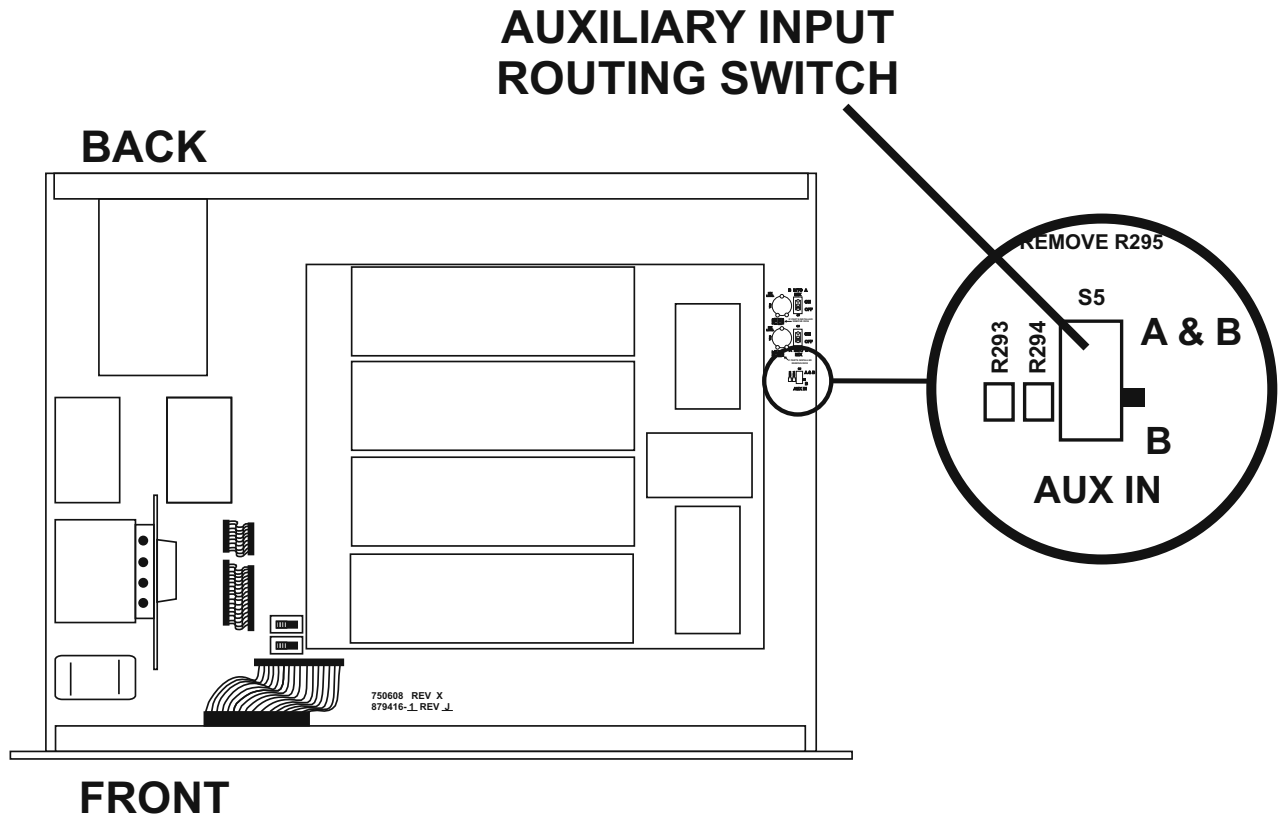
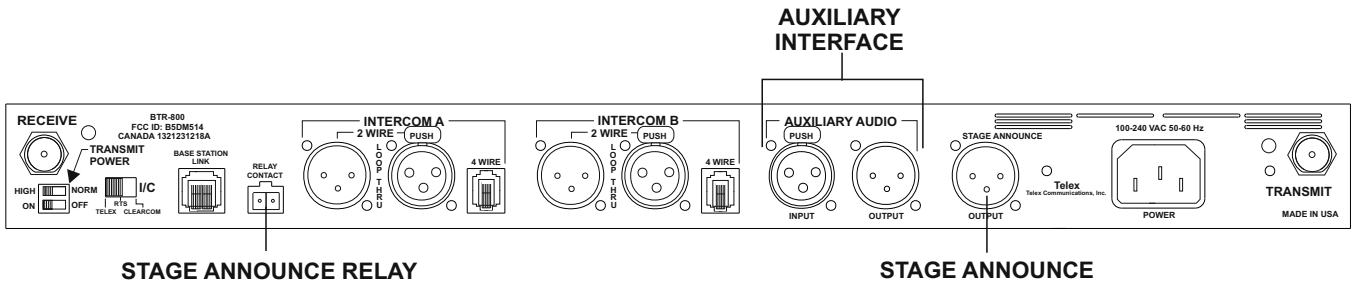


Figure 23  
Auxiliary Input Routing Switch



Base Station - Rear Panel

## Stage Announce / Relay Contacts

The stage announce output connector is where audio exits the base when any of the belt packs press the [SA] button. The output is balanced audio through a male 3-pin XLR. The stage announce output level is set at the factory for 2 Vrms typical output at rated deviation into 600 Ohms. This should be adequate for most applications. There is an internal level adjustment for this output too. See Figure 26 for the location of the small level trimmer. The top cover of the base station must be removed for access.

A relay contact closure is also activated when a belt pack user presses the [SA] button. The contacts are normal open (N.O.). Rating: 1 Amp at 24 volts AC/DC maximum. A "Phoenix" type connector (supplied) plugs into the relay contact port on the rear of the base station. This connector provides a screw-type closure for an easy connection to wires.

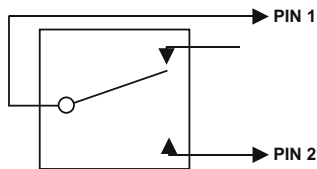


Figure 24  
Relay Output Schematic

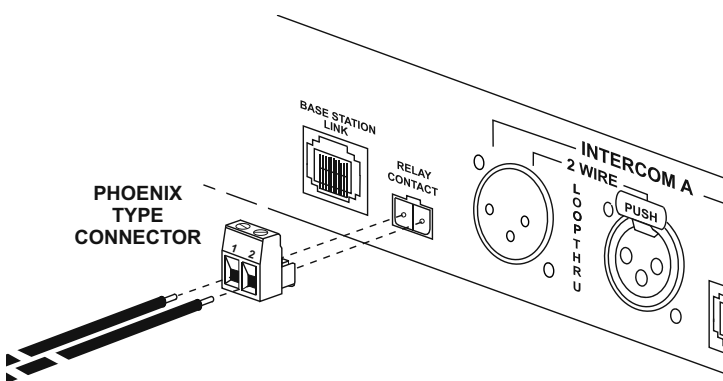


Figure 25  
Relay Contact Jack Adapter  
(Screw Terminal Adapter)

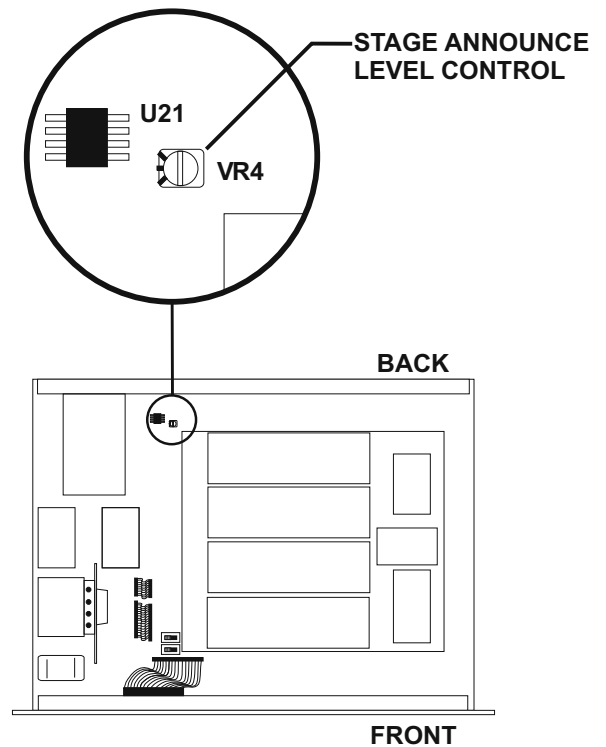
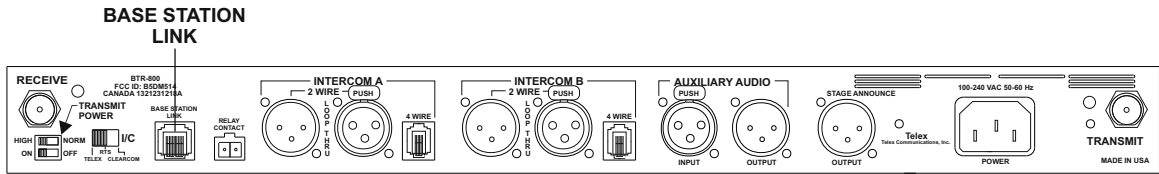


Figure 26  
Internal Stage Announce Level Control



**Base Station - Rear Panel**

**Base Station Link**

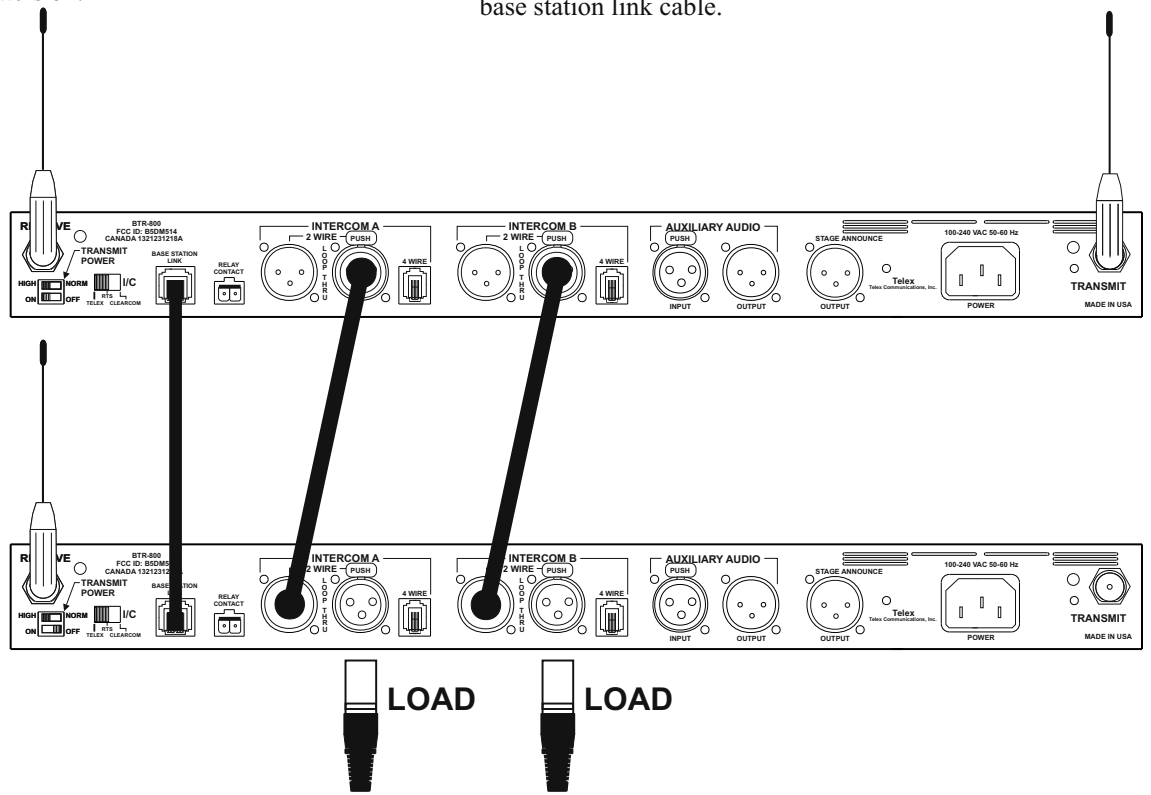
This RJ-45 type jack allows the connection of wireless talk around (WTA) to two base stations of the same frequency bands. This allows WTA on I/C channel A and WTA on I/C channel B to be carried through to the other base station attached together via this jack.

WTA channel A and channel B is “contained” within a base station unless the transmit power is off. If it is off, the WTA audio is routed through the base station link cable to the other base that has its transmitters on.

A cable to accomplish this task is NOT supplied, but can easily be made with common category 5 (CAT-5) wiring.

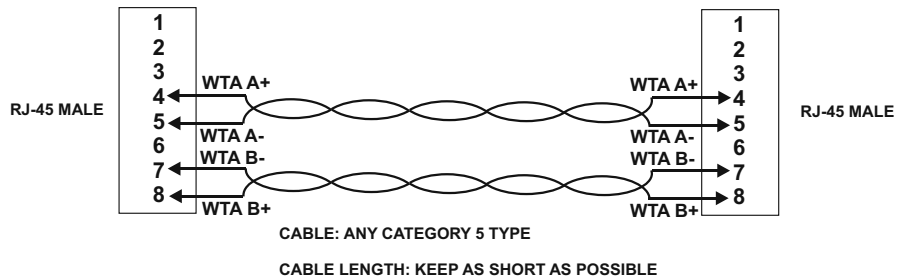
In fact, the most common 10BaseT ethernet patch cables, 568-B wired cables, can be used to connect bases together. The required cable is shown below.

The regular two-wire intercom channels are passed from base to base via the wired intercom cables and do not require the base station link cable.



**Figure 27**

**Two Stand Alone Base Stations Connected Together**

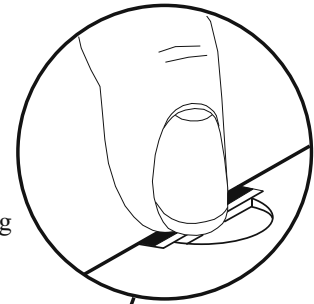


**Figure 28**  
**Base Station Link Cable**

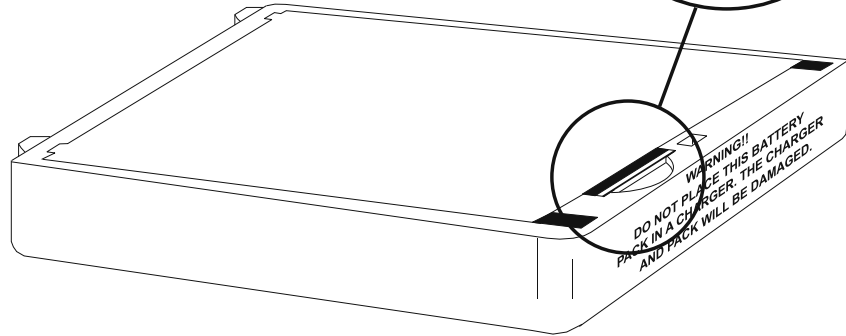
## Beltpack Set-up

### Battery Installation

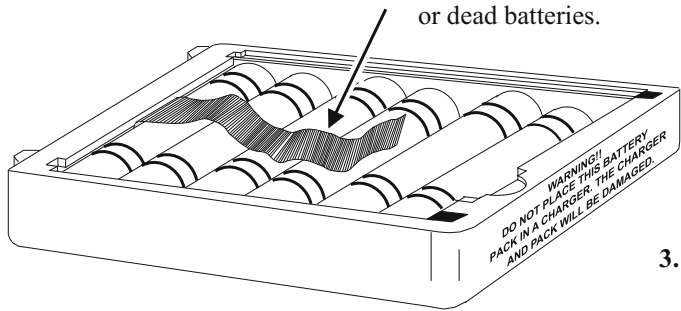
Ensure that the On/Off volume control knob is turned off.  
Press down and hold down the battery release latch, slide the battery pack about 1/8 inch back, toward the latch, until it stops. Then lift battery pack out. Replace batteries as follows:



1. Open the battery pack by inserting finger nail and lifting.



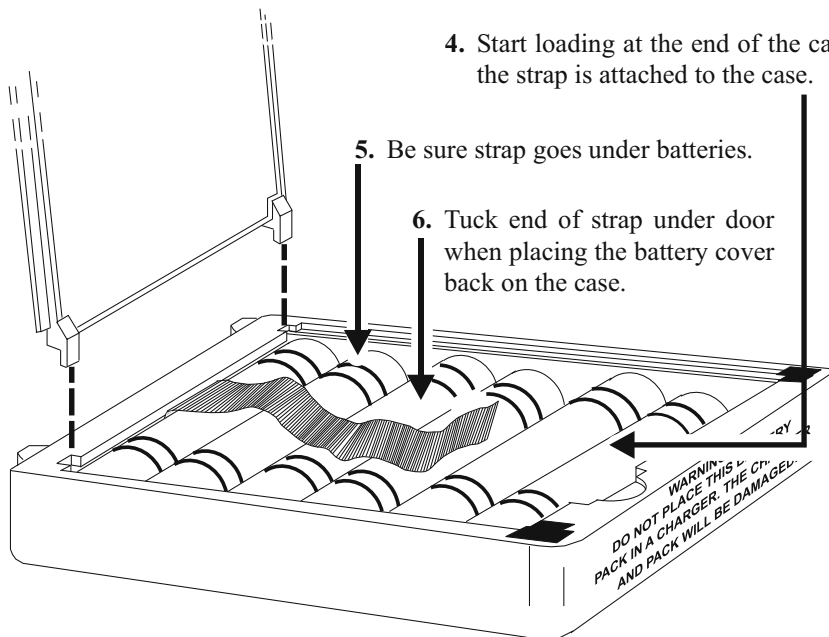
2. Pull battery strap to remove low or dead batteries.



3. Load new batteries following the polarity as shown in battery case



4. Start loading at the end of the case where the strap is attached to the case.



5. Be sure strap goes under batteries.

6. Tuck end of strap under door when placing the battery cover back on the case.

#### WARNING

Do not place an alkaline TR battery pack in any battery charger. Severe charger and battery pack damage may result.

Figure 29  
Battery Installation



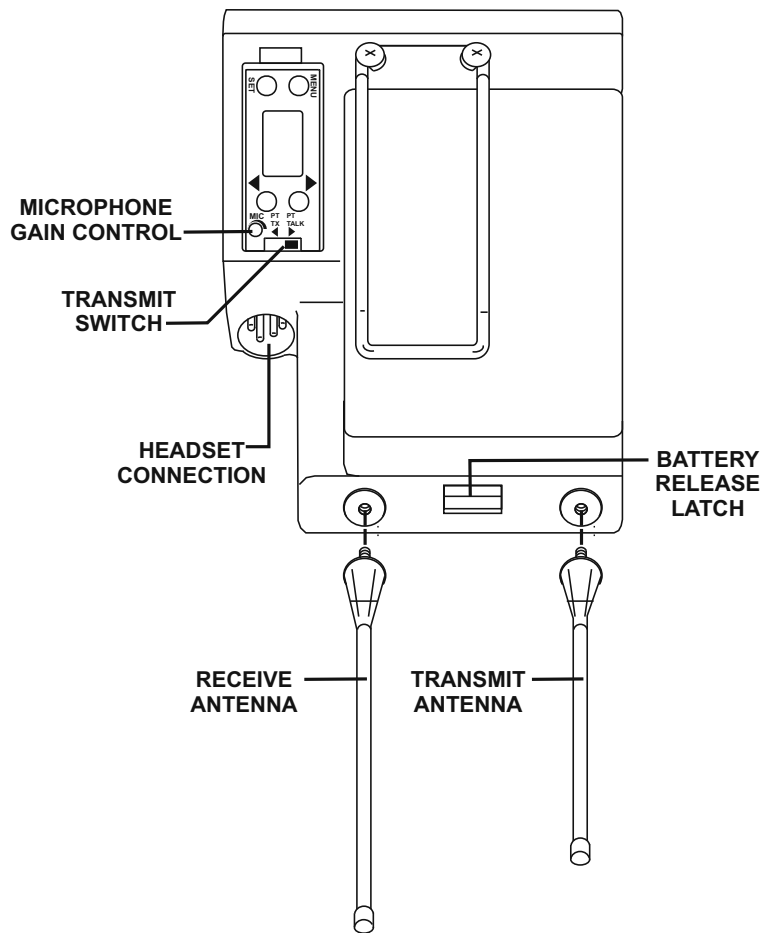


Figure 30  
TR-800 and TR-825 Rear Panel

## Antenna Connection

The belt pack comes with two detachable, screw-type, 1/4-wave antennas. To attach the two antennas, screw into the receptacles at the bottom of the belt pack. The color dot on the screw end of the antenna must match the color dot on antenna receptacle. The receive antenna screws into the left receptacle if the belt pack is laying flat with the battery compartment face up and the antenna receptacles facing you. The other antenna is the transmit antenna. New antennas can be ordered if desired, see the “Accessories” section.

## Transmit mode

The rear panel located transmit switch has the following two modes:

**Push-to-Talk (PT TALK) – Recommended position –**  
The transmitter is always on. No audio is sent unless the talk switch, WTA or SA button is pressed.

**Push-to-Transmit (PT TX) –** The transmitter and audio path are off except when the talk switch, WTA or SA button is pressed.

## Headset Connection

Insert the headset plug into the XLR connector. See the headset pinout in the “TR-800/TR-825” belt pack controls and connections” section if this is not a Telex headset. A dynamic or electret headset microphone is automatically detected by the belt pack and a bias voltage supplied if needed.



# Section 6

## Pre-Walk-Thru Checklist

---

Following the instructions fully to this point you have successfully completed the following checklist:

- Located the base station properly.
- Connected power to base station.
- Connected the 1/2-wave antennas to the base station. Checked frequency range of the antennas with the frequency of the base station by correctly matching color codes.
- Connected 1/4-wave antenna to the beltack. Checked frequency range of the antennas with the frequency of the beltack by correctly matching color codes.
- Base station transmit power switches in the correct positions.
- Transmit mode switch on beltack set correctly
- Set wired intercom type correctly.
- Connected headsets to base stations (if needed) and all beltacks.
- Connected the base station to any auxiliary audio, intercom, external P.A. system, or relay contact detect circuit if needed
- Installed batteries in the beltack.
- If you missed any of the above instructions, go back and complete that instruction before going on.



### Frequency Plan Overview

The BTR/TR-8XX has 36 factory defined frequency groups and 12 user-programmable frequency groups. A **Group** defines the two base station transmit frequencies and thus the two receive frequencies on all the beltpacks. A **Channel** defines a base station receive frequency and thus a beltpack transmit frequency. A base station receive channel that does not have a frequency set for it will have a dash to the right of it on the Group/Channel select screen. Details on setting frequencies may be found in the “BTR-800 Menu Structure” and “TR-8XX Menu Structure” instructions in this section.

### Factory-Defined Groups

The 36 factory-defined groups were carefully chosen to avoid certain intermod products and various other possible sources of interference. The Groups are set and cannot be changed. There is a limited number of channels which can be chosen from within these groups.

The first 24 factory-defined groups (01A – 12B) are “pair” groups that can be used for single (up to 4 beltpacks) and dual (up to 8 beltpacks) BTR-800 systems. They are arranged 01A, 01B, 02A, 02B...011B, 012A, 012B. A “pair” group, like 1A and 1B, have different base station transmit frequencies, however, they both have the same eight base station receive channels from which to choose. Each channel represents a unique frequency. For example, one BTR-800 could be set on Group 02A and channels 01, 02, 03 and 04. The other BTR-800 could be set on Group 02B channels 05, 06, 07 and 08. As long as the channels are different, everything should be fine.

The next 12 groups (13 – 24) are single groups that primarily are used for single (up to 4 beltpacks) BTR-800 systems. The number of channels from which to choose from in these groups will vary from group to group.

### User-Programmable Groups

The 12 user-programmable groups are initially empty. The transmit and receive frequencies are fully editable within these groups. In fact, factory-defined groups may be copied to user-programmable groups and then edited if desired. See the “BTR-800 Menu Structure” and “TR-8XX Menu Structure” instructions in this section for details on how to copy and edit frequencies.

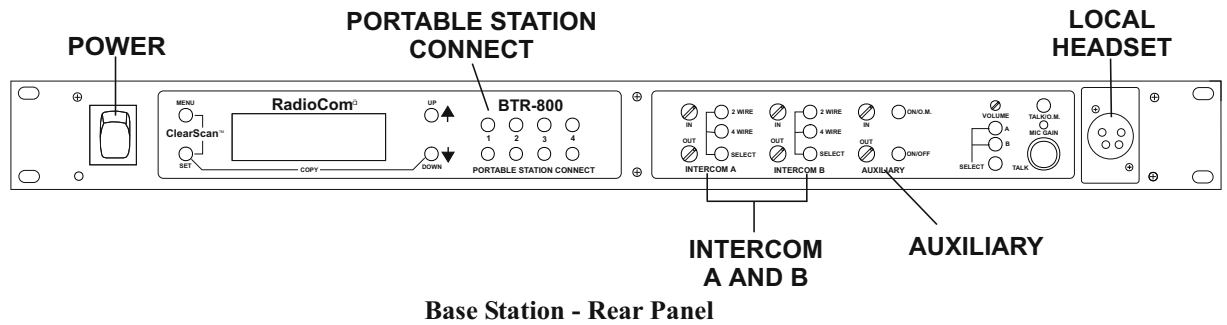
### System Quick Start

Follow the list below to quickly get a base station and beltpack(s) operating. When completed the user should have a base station and 1 to 4 beltpacks up and running with full operational ability. The base station will be on Group 01A with its four receivers on channels 01, 02, 03 and 04. Each beltpack will be on Group 01A with a unique transmit channel number matching one of the base station receive channels.

1. Plug-in the base station via the supplied power cord and connect the antennas. The color dots on the base should match the color rings on the antennas.
2. Base station rear panel switches: Transmit power set to High and on.
3. Ensure base station rear panel IC switch matches attached wired intercom system. If used stand alone or connected to a 4-wire system then IC switch position is Not Applicable.
4. Press [MENU] as powering-up the base station. This will place it on group 01A and set the receives on channels: 01, 02, 03, and 04.
5. Place the front panel IC A and IC B “IN” and “OUT” level controls in the 12:00 o’clock position. Check that front panel IC A and B is in 2-wire for AudioCom (Telex), RTS -TW and ClearCom wired systems, and 4-wire for RTS Matrix and stand-alone operation.
6. Place batteries in the beltpacks.
7. Remove the rear switch cover on the beltpacks. Set the beltpack rear panel slide switch to push-to-talk (PT TALK).
8. Press [MENU] as powering-up each beltpack. This will place the beltpack on group 01A with the channel 01 flashing.
9. Use the [UP] and [DOWN] arrow buttons to change the channel to match a channel on the base station. Then press [SET]. If leaving on channel, just press [MENU]. Each beltpack should have a unique channel number.
10. The group/channel on the beltpack should now match the group and a receive channel on the base station. Nothing should be flashing on the beltpack screens.
11. Plug headsets into the beltpacks and set the microphone gain so the BAT/OM LED will flash at the beginning of most words at normal speech levels.

**DONE.**

## Base Station Operation



Base Station - Rear Panel

### Power

If you have followed the instructions in Section 4, “Initial Equipment Set-Up”, you should now be ready to turn the base station on.

Set the base station power switch to the on position, by pushing the top of the switch. The internal cooling fan will start immediately and the LCD display and front panel indicator lights will come on in five or six seconds.

### Local Headset

**Talk Button** - Press to enable the audio path from the local headset. The TALK/O.M. LED will turn green when audio is enabled. A quick press and release latches on the button. If the talk function is latched on, pressing the talk button again will turn it off. If the local headset is not being used, the talk button should be off. This keeps additional noise out of the system.

**Microphone Gain** - Adjusts the headset’s microphone gain. Adjust so the TALK/O.M. LED flashes from green to red on loudest speech.

**Headset Intercom Select Button** - Select the intercom system to connect to the local headset. Each press of the [SELECT] button changes the connection; Channel A, Channel B and Both. The cycle will then repeat. The LEDs above the [SELECT] button light to indicate the current selection.

**Volume** - Adjust the volume to the headset by rotating the volume control as required for a comfortable listening volume.

### Portable Station Connect

Select the audio paths from the base station’s four receivers that you wish to enable. The corresponding LED above the select button is on when the audio path is enabled. If a belt-pack user has their portable station connect path off at the base, that user will no longer hear their sidetone and their audio will not be passed to anyone. The user will still be able to hear everyone. The selection is retained in non-volatile memory, so it will come-up where last left if the unit is power cycled.

Always disable unused audio receive paths. This reduces the chances that external RF noise can get onto the audio buses via an open receiver.

### Intercom A and B

**Intercom Select Button** - Press the [SELECT] button to choose between 2-wire or 4-wire intercom systems. The green LED will indicate the current mode of the intercom channel. If the base station is connected to a 2-wire system, such as Audiocom (Telex), RTS TW or Clear-Com®, set the intercom to 2-wire. If it is connected to a four-wire system, such as RTS Matrix, set the intercom to 4-wire. It is also possible to have intercom A connected to a 2-wire system and intercom B connected to a 4-wire system or vice versa. The selection is retained in non-volatile memory, so it will come-up where last left if the unit is power cycled.

**In Level Control** - Adjusts the audio level of the wired intercom system’s input to the base station.

**Out Level Control** - Adjusts the audio level of the base station’s output to the wired intercom system.

If the base station is used stand-alone, no wired intercom system connected, it must be set in the 4-wire mode. The 2-wire mode requires a wired intercom system or appropriate load be connected to the intercom A or B XLRs. If not loaded, a large gain increase will take place in the unload intercom channel which may be high enough to produce a loud “howling” sound.

### Auxiliary

**Auxiliary Input Select Button** - Press the [SELECT] button to turn on or off the auxiliary input to the base station. The selection is retained in non-volatile memory, so it will come-up where last left if the unit is power cycled.

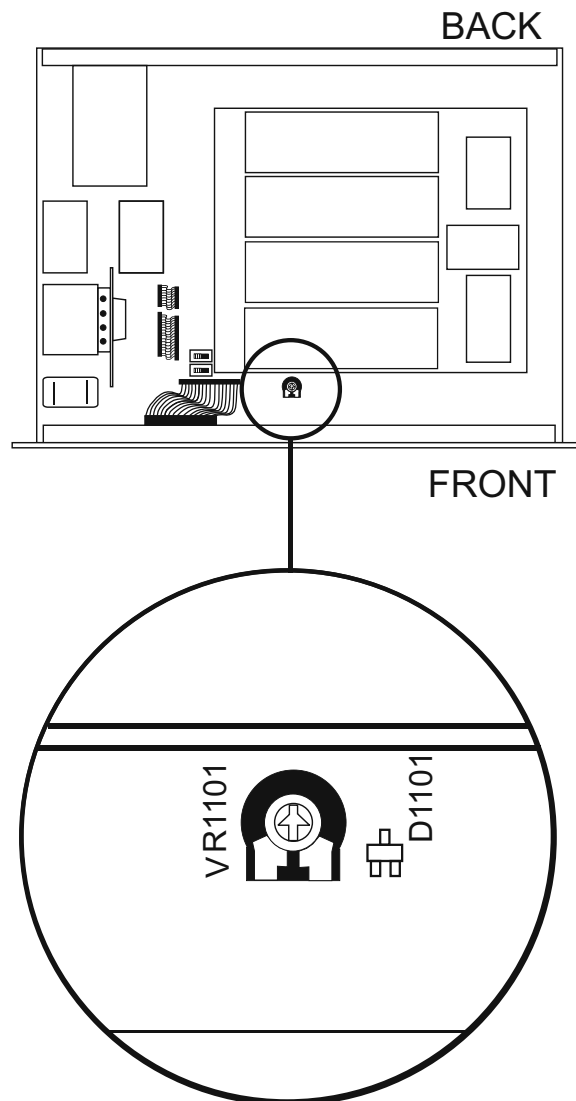
**In Level Control** - Adjusts the audio level of the wired auxiliary system’s input to the base station.

**Out Level Control** - Adjusts the audio level of the base station’s output to the auxiliary XLR plug.

The auxiliary output connects only to intercom B. It does not interface to intercom A. The auxiliary input may be switched to B intercom (default) or A and B intercom. See Section 5 for the location of this internally located input routing switch. The auxiliary output is always available at the back panel output XLR. It cannot be switched on or off like the input. Both the input and output are balanced audio ports. Auxiliary input and output audio is global. See Section 5 for more details.

## Display Contrast

The LCD's (Liquid Crystal Display) contrast is set from the factory to a standard level. However it is possible for the user to adjust the contrast if desired. The contrast control is internal to the BTR-800 unit near the front panel. The cover must be removed for access to this control. Please see Figure 31 for the location.

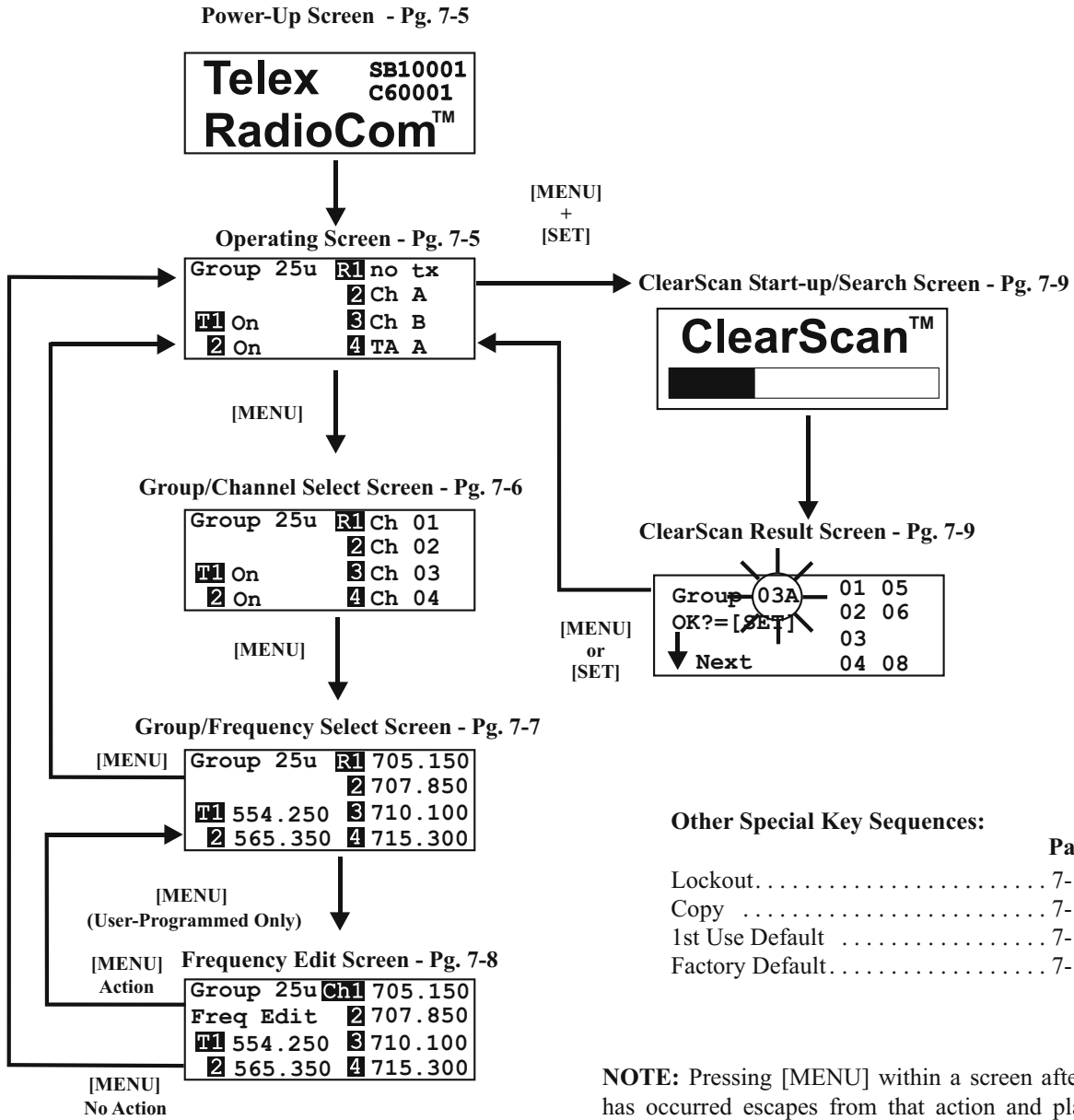


**Figure 31**  
**LCD Contrast**

# BTR-800 Menu Structure

## Main Screen Flowchart

The following contains the base station menu structure and references the pages in which further detail of that menu may be found.



**Other Special Key Sequences:**

	Page
Lockout.....	7-10
Copy .....	7-10
1st Use Default .....	7-10
Factory Default.....	7-10

**NOTE:** Pressing [MENU] within a screen after action has occurred escapes from that action and places the user at the current screen. Any editing that had been done since [SET] had been pressed is aborted.



## Power-Up Screen

- This screen is displayed only on power up, first use default and factory default.
- The 1<sup>st</sup> upper right corner number displays the base's software revision. The single version number increments for changes in operational software.
- The 2<sup>nd</sup> upper right corner number displays the base's channel map (frequency plan) version. The single version number increments for changes in the channel map.
- Once the power-up screen is displayed, it will change to the operating screen after a few seconds.

## Operating Screen

- Screen is displayed after power-up screen.
- System will revert to this screen if no activity is detected on the LCD display buttons after 3 minutes.
- Screen displays current status of the system.

## Beltpack Activity Code Definitions:

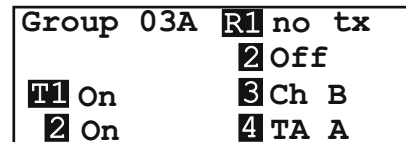
no tx = No Beltpack Transmit Carrier Detected  
Off = Receiver is not selected on front panel  
Ch A = Beltpack audio is on Channel A  
Ch B = Beltpack audio is on Channel B  
Ch A&B = Beltpack audio is on Channel A and B (TR-825 only)  
TA A = Beltpack Channel B Talk Around Active  
TA B = Beltpack Channel A Talk Around Active  
TA A&B = Beltpack Channel A and B Talk Around Active (TR-825 only)  
SA = Beltpack Stage Announce Active

**NOTE:** Older versions of BTR-800 software do not support the detection of TR-825 "Ch A&B" and "TA A&B" control tones.

## Power-Up Screen



## Operating Screen



## Group / Channel Select

The Group/Channel select screen allows the user to change the group and select from a pre-determined number of channels on each receiver.

- Hit [MENU] once to enter the Group / Channel Select Screen from the operating screen.
- Hit [SET] to enter group edit. The group number will start flashing. If [SET] is hit again without hitting the arrows, the display will go to receive 01 channel edit. **NOTE:** A channel that does not have a frequency set for it will have a dash to the right of it on the group/channel select screen.
- The [UP] / [DOWN] arrows will change the group number. Hit [SET] again to set the group that was flashing. Now the group number will stop flashing and R1's channel number will start to flash.
- The [UP] / [DOWN] arrows will change the receive channel number. Hit [SET] to set the channel that was selected. Now the second channel number will start to flash. If [SET] is hit again without hitting the arrows, the display will go to the next channel number.
- After the last receive channel is decided upon, hitting [SET] will set that channel in the unit and start you over at the beginning of the group/channel select screen with nothing flashing.
- Hitting [MENU] will take you to the group/frequency select screen. **NOTE:** Hitting [MENU] after activity has occurred within the screen will return to the group/channel select screen with nothing flashing. Any change that had been done before the last [SET] was pressed will be aborted.
- Setting two channels the same is not allowed. If a channel is already set on the screen, the user no longer has that channel as an option to set into one of the other receivers.

## Group / Channel Select

Group 14	R1	Ch 01
	2	Ch 02
T1 On	3	Ch 03
2 On	4	Ch 04

[SET]

Group 14	R1	Ch 01
	2	Ch 02
T1 On	3	Ch 03
2 On	4	Ch 04

[UP] / [DOWN]  
[SET]

Group 15	R1	Ch 01
	2	Ch 02
T1 On	3	Ch 03
2 On	4	Ch 04

[UP] / [DOWN]  
[SET]

Group 15	R1	Ch 05
	2	Ch 02
T1 On	3	Ch 03
2 On	4	Ch 04

[UP] / [DOWN]  
[SET] (Last Rx Changed)

Group 15	R1	Ch 05
	2	Ch 06
T1 On	3	Ch 07
2 On	4	Ch 08

[MENU]

Group 15	R1	715.000
	2	716.700
T1	568.500	3 719.700
2	569.700	4 721.600

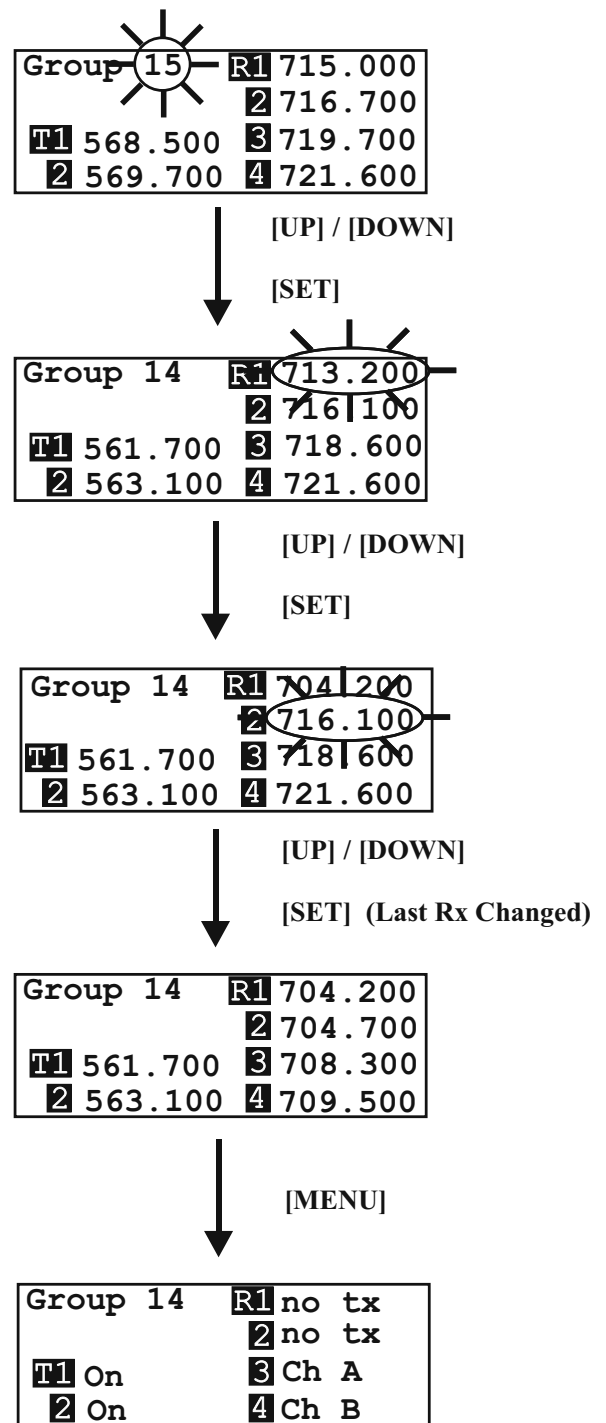
END

## Group / Frequency Select

The Group/Frequency select screen allows a user to set the group and select from a pre-determined number of frequencies on each receiver. Each frequency displayed on the right half of the screen corresponds to a channel number in the Group/Channel Screen.

- Press [MENU] twice to go to the Group / Frequency Select screen from the operating screen. Hit [SET] to start the group number flashing.
- Press the [UP] / [DOWN] arrows to change the group number. The frequencies listed will reflect what is currently in that group. Hitting [SET] will select the group and start the selecting of predetermined frequencies within that group. The R1 frequency will start flashing. **NOTE:** The group number sets the transmit frequencies of factory defined groups and these are not editable. In user-programmed groups these are editable from the frequency edit screen.
- Pressing the [UP] / [DOWN] arrows will change the frequency of "R1" to the pre-defined frequencies available. Hitting [SET] will accept the change and start you editing the next channel. If you had not hit the arrow keys when the frequency was flashing, but instead hit [SET], you would have skipped to the next frequency to edit.
- After the last receive frequency is decided upon, hitting [SET] will save that last frequency and start you over at the beginning of the group/frequency select screen with nothing flashing.
- Pressing [MENU] will take you to the operating screen if this is a factory-defined group. If within a user programmed group, you will be taken to the frequency edit screen. **NOTE:** Hitting [MENU] after activity has occurred within the screen will return to the group/frequency edit screen with nothing flashing. Any change that had been done before the last [SET] was pressed will be aborted.

## Group / Frequency Select



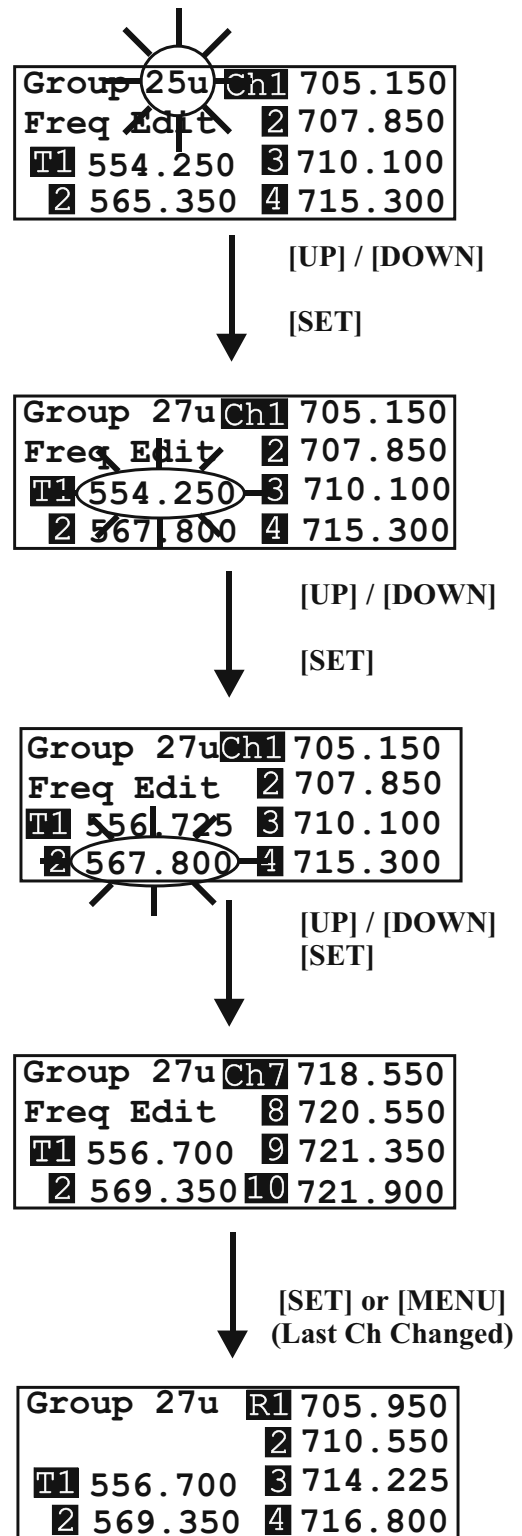
END

## Frequency Edit (User-Programmed Groups Only)

This menu only occurs for user-programmable groups or when copying to a user-programmable group. The Frequency Edit screen allows the user to set the group transmit frequencies and receive channel frequencies of a user-programmable group.

- Press [MENU] three times to go to the frequency select screen from the operating screen. Press [SET] to start the group number flashing. This screen allows the user to set the group and frequencies of user-programmed groups only.
- Press the [UP] / [DOWN] arrows to change the group number. The frequencies listed will reflect what is currently in that group. Dashes will be displayed in any slots that are not defined yet. Pressing [SET] will select the group and start the selecting of frequencies within that group. The T1 frequency will start flashing.
- Pressing the [UP] / [DOWN] arrows will change the frequency of "T1" in 25kHz steps. Pressing [SET] will accept the change and start you editing T2. If you had not hit the arrow keys when the frequency was flashing, but instead press [SET], you would have skipped to the next frequency to edit.
- After editing the transmit and the receive channel frequencies, pressing [SET] will save that last frequency and send you over to the beginning of the group/frequency select screen with nothing flashing. **NOTE:** Once the end of the displayed channel list is reached, the last displayed channel location will scroll to allow the user to edit the remaining channels.
- After action has occurred in the frequency edit screen hitting [MENU] will take you one menu back to the group/frequency select screen so that the user may see what frequencies the base receivers are now on. If no action had occurred, then pressing [MENU] will take you to the operating screen. **NOTE:** Besides a group change, any editing that occurs within this screen to frequencies DOES NOT take effect until the user exits the screen via setting the last channel or pressing [MENU].

## Frequency Edit (User-Programmed Groups Only)



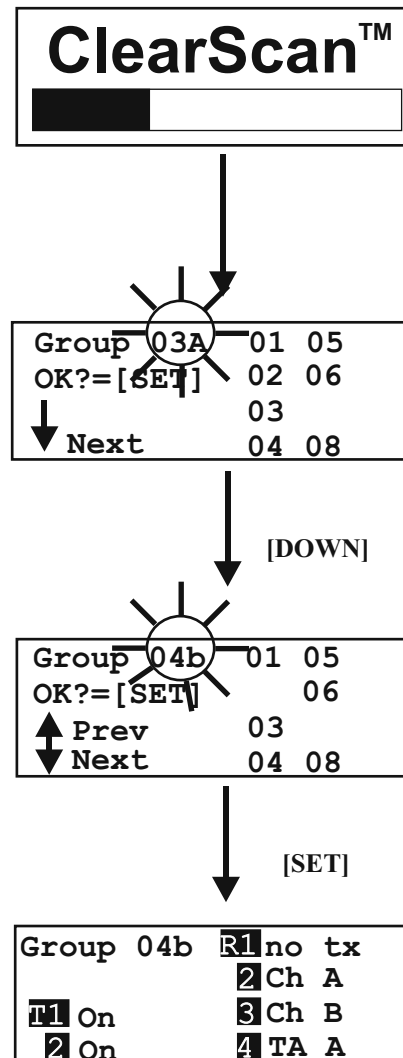
END

## ClearScan™

ClearScan™ performs a frequency scan of the factory-defined and any set-up user-programmable groups in order to find the group with the highest number of clear receive channels. After about 20-30 seconds, the group with the highest number of clear receive channels will be displayed. The next best group and so forth may be accessed with the [DOWN] and [UP] arrow buttons.

- Press and hold [MENU] + [SET] for three seconds to enter ClearScan™. The base station will now start searching all groups for the ones with the greatest number of receiver channels clear of interference.
- ClearScan™ will display the group that has the most interference free receive channels. These clear channels are displayed on the right half of the screen. Press [SET] to place the base station on this group and return to the operating screen. The first four receive channels displayed will be the ones set for the group. The [UP] / [DOWN] buttons may be used to select the next best group and so forth.

## ClearScan™



END

## Special Key Sequences

### Lockout

- Press [UP]+[DOWN] for 3 seconds to lock or unlock the base station. Pressing [MENU] will still function to view screens, but [SET] will no longer start any editing. ClearScan™, First use, Factory default are no longer accessible. The intercom channel A and B front panel 2-wire/4-wire selection is also locked into place. A padlock icon will be displayed on the second line of the display to the far left as an indication that the base station is locked out.

### Copy

- Press [SET]+[DOWN] for 3 seconds to copy any currently displayed group to a user-programmable group. Copy can be done from the group/channel select, group/frequency select or frequency edit screen. Once pressed, the words, “Copy to” are displayed on the screen with the first empty user-programmable group flashing. If all the user-programmed groups were full, than the first programable group is displayed. The [UP] or [DOWN] buttons may be used to select a different user-programmable group if desired. Pressing [SET] pastes frequencies/channels to the group and take the user to the frequency edit screen with “T1” flashing.

### 1<sup>st</sup> Use Default

- Press [MENU] while turning on the base station to enter the 1<sup>st</sup> use default setup screen. This places the unit on group 01A with the four receivers set to channels 1- 4 of the group. **Any user-programmed frequencies that had been entered previously are retained.** If lockout had been activated, the beltack comes up where it was last left regardless of [MENU] being pressed on power-up.

### Factory Default

- Pressing all four buttons [MENU]+[SET]+[UP]+[DOWN] at the same time for 3 seconds places the unit on group 01A with the four receivers set to channels 1 – 4 of that group. This is just like base station 1<sup>st</sup> use default, except that **all user-programmed frequencies that had been entered previously are erased.** This function may take several seconds. If lockout had been activated, the beltack comes up where it was last left regardless of these four keys being pressed.

## Beltpack Operation

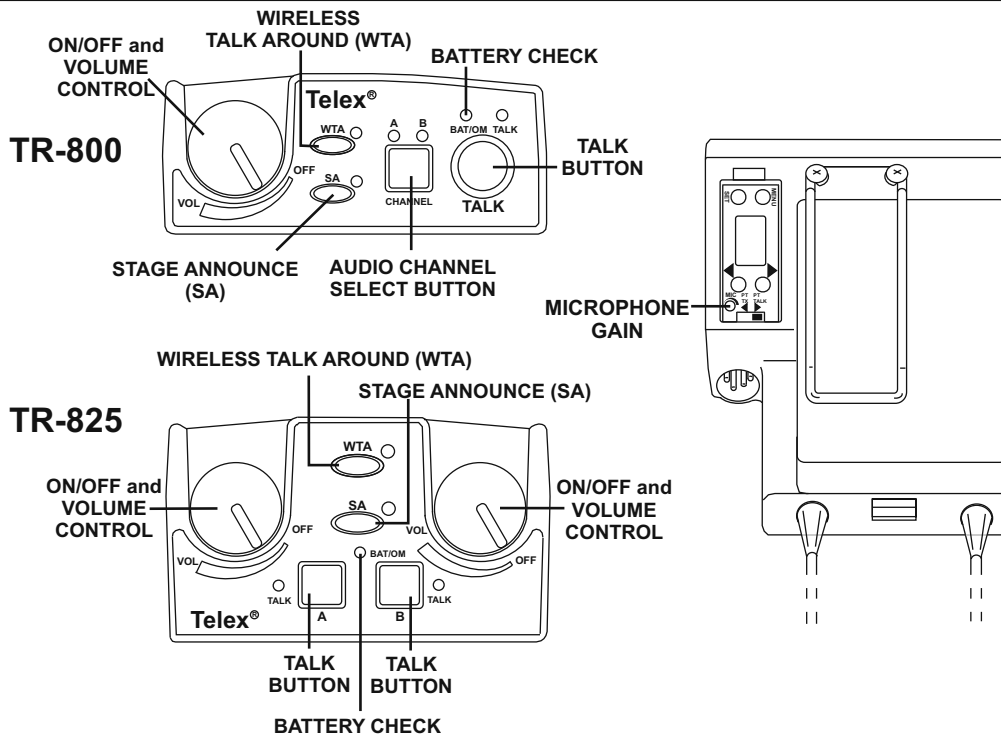


Figure 32  
TR-800 and TR-825 Top and Rear Panel

### On/Off and Volume Control

Turn the beltpack power on by rotating the knob CW. Adjust the volume to the headset by rotating the volume control as required for a comfortable listening volume.

### Battery Check

When the beltpack power is turned on by rotating the knob, the BAT/OM LED will flash once if the battery is good. If the LED stays on, the battery is low. If the LED does not flash, the battery is dead.

### Talk Button

Press the talk button to enable the audio path from the headset microphone. The TALK/OM LED will turn red when audio is enabled. A quick press and release latches the talk function unless latching has been disabled. Holding the button for over ½ a second will cause the audio path to be enabled only for as long as the button is held. If the talk function is latched on, pressing the talk button again will turn it off. See the “Talk Button Latching/Non-Latching” instructions in Section 7 to learn how to enable/disable latching of the talk button.

### Microphone Gain

Adjusts the headset’s microphone gain. Adjust so the TALK/OM LED flashes red at the beginning of most words at normal speech levels. If the input is too large, the LED will be red during the complete word at normal speech level. The peak-responding audio limiter in the beltpack is very tolerant of high input audio levels. Even when the microphone gain is maximized, and headset volume reduced to make up for the louder audio, the audio will still sound good and not clipped.

### Audio Channel Select Button

Selects the intercom system to which the headset is connected. The LED near the channel button indicates the current selection. See the “Audio Channel A/B Enable/Disable” instructions in Section 7 to learn how to enable only channel A, channel B, or both.

### Stage Announce (SA)

When pressed the audio from the beltpack is routed directly to the stage announce connector on the back of the base station. The base station’s SA relay is also closed. The beltpack sidetone is lost as an indication that stage announce is activated. The other beltpacks and wired users do not hear this beltpacks audio when SA is pressed. The button is non-latching and activates the nearby red LED when pressed. See the “Stage Announce Enable/Disable” instructions in Section 7 to learn how to enable/disable the SA button.

### Wireless Talk Around (WTA)

When pressed, the audio from the beltpack is disconnected from the wired intercom, auxiliary input/output and the base station’s local headset. Other beltpack users, on that audio channel, can hear the user as normal. The button activates the nearby red LED as well as the appropriate talk LED when pressed. See the “Wireless Talk Around Enable/Disable” instructions in Section 7 to learn how to enable/disable the WTA button as well as other features.

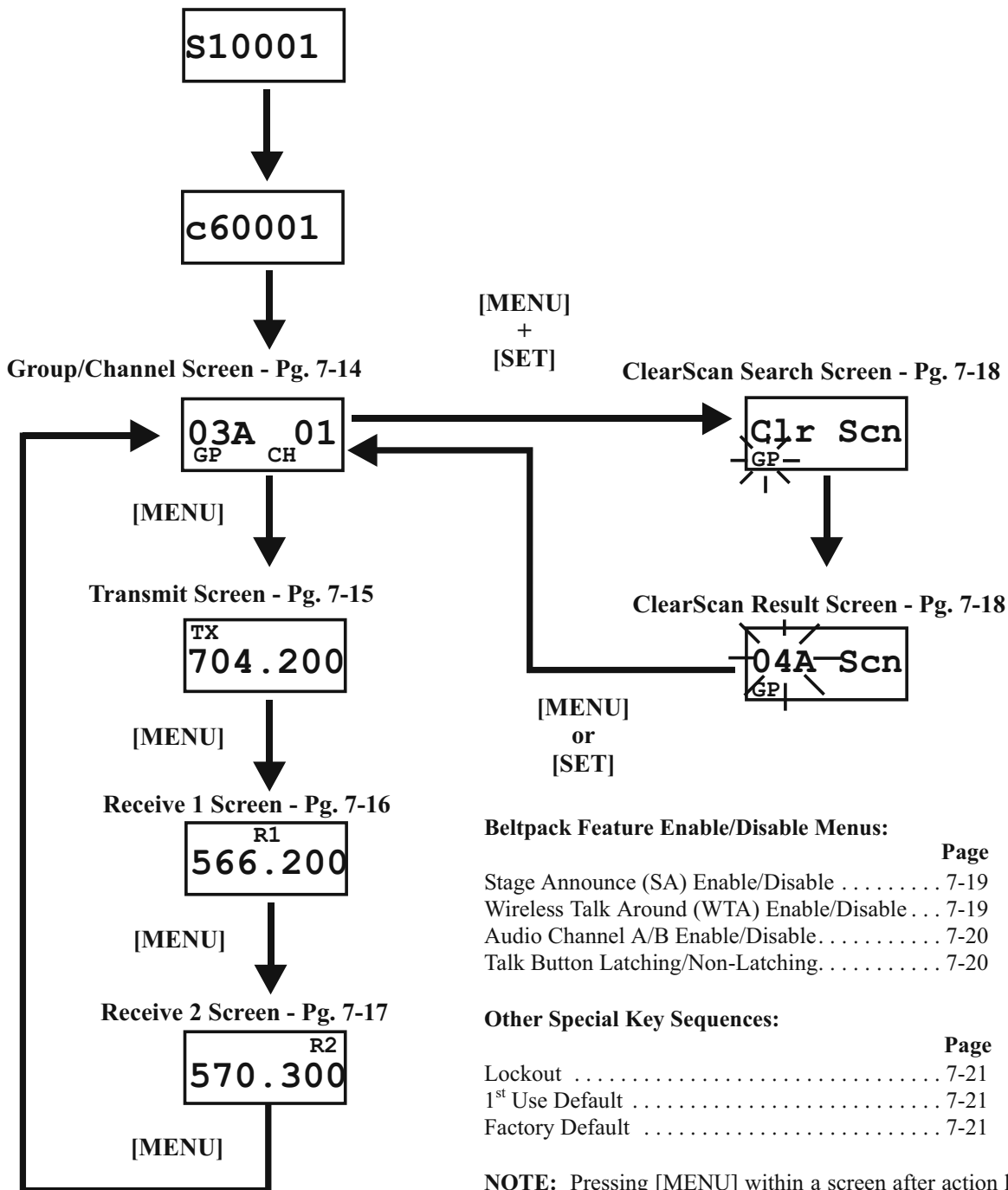
# TR-800 Menu Structure

## Beltpack Menu Structure

The following contains the main beltpack menu structure and references the pages in which further detail of that menu may be found.

All beltpack features and special key sequences can only be done from the group/channel screen.

### Power-Up Screen - Pg. 7-13



### Beltpack Feature Enable/Disable Menus:

	Page
Stage Announce (SA) Enable/Disable . . . . .	7-19
Wireless Talk Around (WTA) Enable/Disable . . .	7-19
Audio Channel A/B Enable/Disable. . . . .	7-20
Talk Button Latching/Non-Latching. . . . .	7-20

### Other Special Key Sequences:

	Page
Lockout . . . . .	7-21
1 <sup>st</sup> Use Default . . . . .	7-21
Factory Default . . . . .	7-21

**NOTE:** Pressing [MENU] within a screen after action has occurred escapes from that action and places the user at the current screen. Any editing that had been done since [SET] had been pressed is aborted.



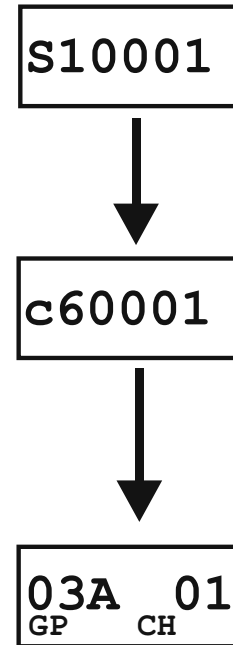
## TR-800 Menu Structure

---

### Power-Up Screens

- The first screens displayed when the beltpack is powered up are the software and channel map version screens.
- The 1<sup>st</sup> screen displayed indicates the beltpack's software version number. It is displayed for about one second.
- The 2nd screen displayed indicates the beltpack's channel map (frequency plan) version number. It is displayed for about one second.
- The final screen displayed is the group/channel screen

### Power-Up Screens



**END**

## TR-800 Menu Structure

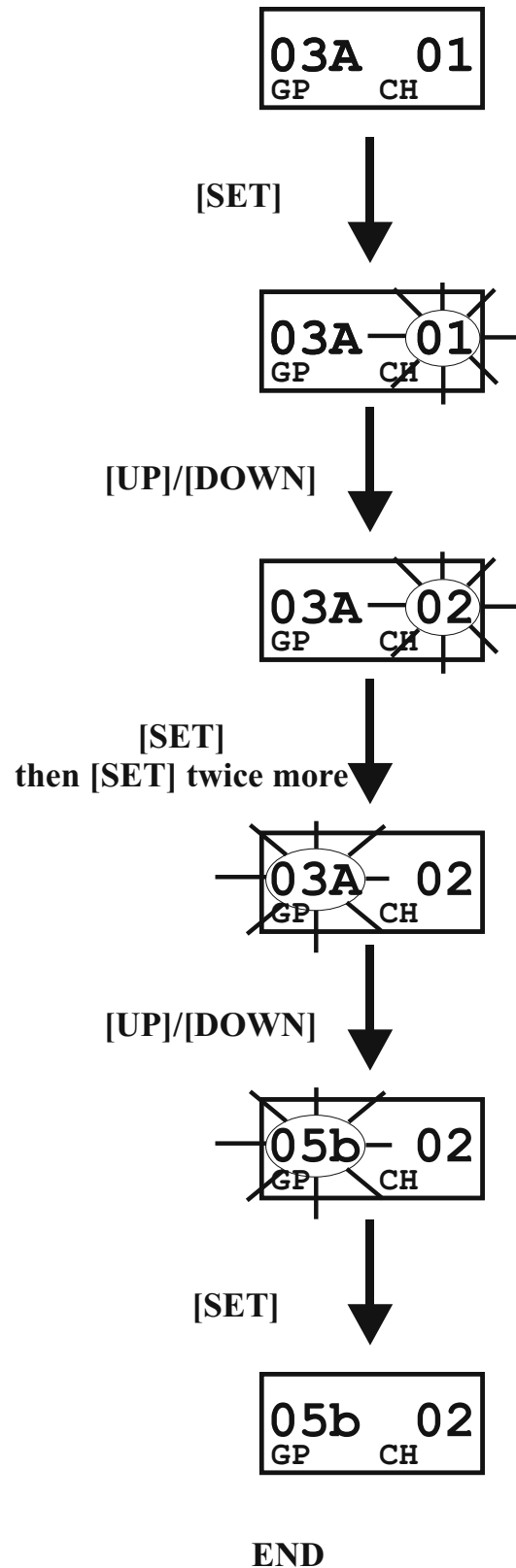
---

### Group / Channel Screen

The Group/Channel screen allows the user to change the group and select from a pre-determined number of transmit channels.

- The screen displayed after the beltpack power-up screens.
- Press [SET] to edit the channel number. The channel number will start flashing.
- Use the [UP]/[DOWN] arrow buttons to change the channel number.
- Press [SET] to place the beltpack on the channel selected. Once set is pressed, the beltpack transmitter will move to that frequency and nothing will be flashing. Now press [SET] twice to enter group edit.
- Use the [UP]/[DOWN] arrow buttons to change the group number.
- Press [SET] to place the beltpack on the group selected. Once set is pressed, the unit returns to the group/channel display with nothing flashing.
- Pressing [SET] once more will start the editing sequence over again. Pressing [MENU] during the group edit will end editing and send the user back at the group/channel screen without any changes. This applies to channel editing too.

### Group / Channel Screen



# TR-800 Menu Structure

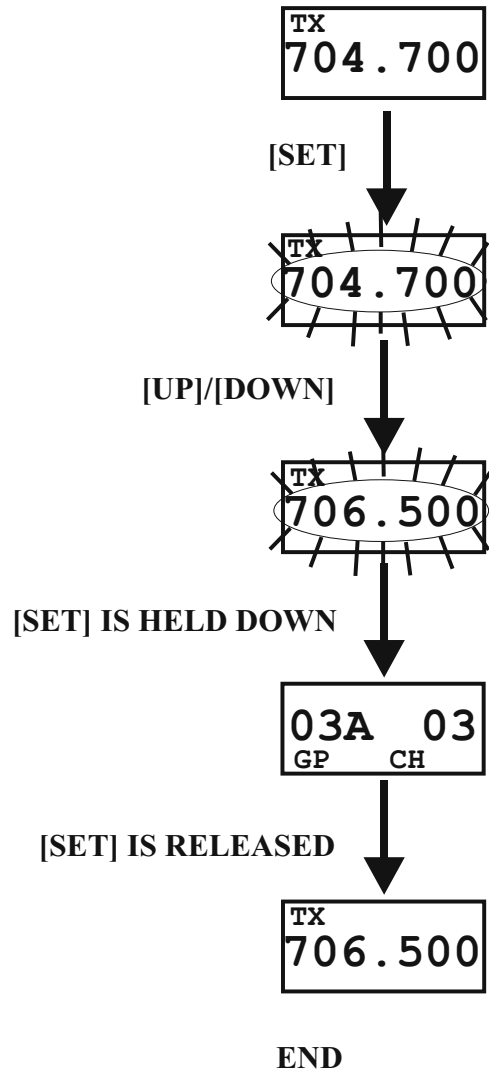
---

## Transmit Screen

The Transmit screen allows the user to set the beltpack transmit frequency. Factory-defined groups will allow only a set number of pre-defined frequencies to be selected. User-programmable groups will allow the user to change the frequency in 25kHz steps.

- Press [MENU] once from the group/channel screen to arrive at the transmit frequency screen.
- Press [SET] to edit the frequency. The number will start flashing.
- Use the [UP]/[DOWN] arrow buttons to change the frequency.
- Press [SET] to place the beltpack on the frequency selected. If set is held down, during that time the group/channel is displayed so the user is aware of what transmit channel the unit has been placed. Once set is released, the unit returns to the transmit frequency screen with nothing flashing.
- Pressing [SET] once more will start the editing sequence over again. Pressing [MENU] during transmit frequency edit will end editing and send the user back to the transmit screen without any changes.

## Transmit Screen

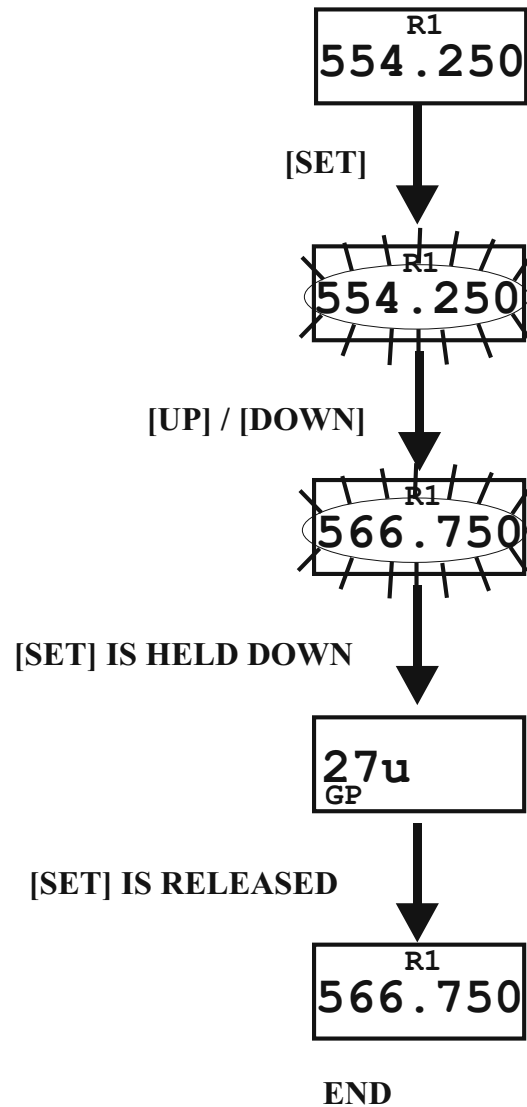


## Receive 1 Screen

The Receive 1 screen allows the user to set the beltback receive 1 frequency. This corresponds to the base station's transmit 1 frequency. In factory-defined groups receive 1 is not changeable. User-programmable groups will allow the user to change the frequency in 25 KHz steps.

- Press [MENU] twice from the group/channel screen to arrive at the receive 1 frequency screen.
- (User-Programmable Groups Only) Press [SET] to edit the frequency. The number will start flashing. Factory-defined groups can't be changed; so pressing set will do nothing at this screen. User-programmed groups will start flashing and allow the user to change the frequency in 25kHz steps.
- (User-Programmable Groups Only) Use the [UP]/[DOWN] arrow buttons to change the frequency.
- (User-Programmable Groups Only) Press [SET] to place the beltback on the frequency selected. If set is held down, during that time the group is displayed so the user is aware of what group the unit has been placed. Once set is released, the unit returns to the receive 1 frequency screen with nothing flashing.
- (User-Programmable Groups Only) Pressing [SET] once more will start the editing sequence over again. Pressing [MENU] during receive 1 frequency edit will end editing and send the user back to the receive 1 screen without any changes.

## Receive 1 Screen

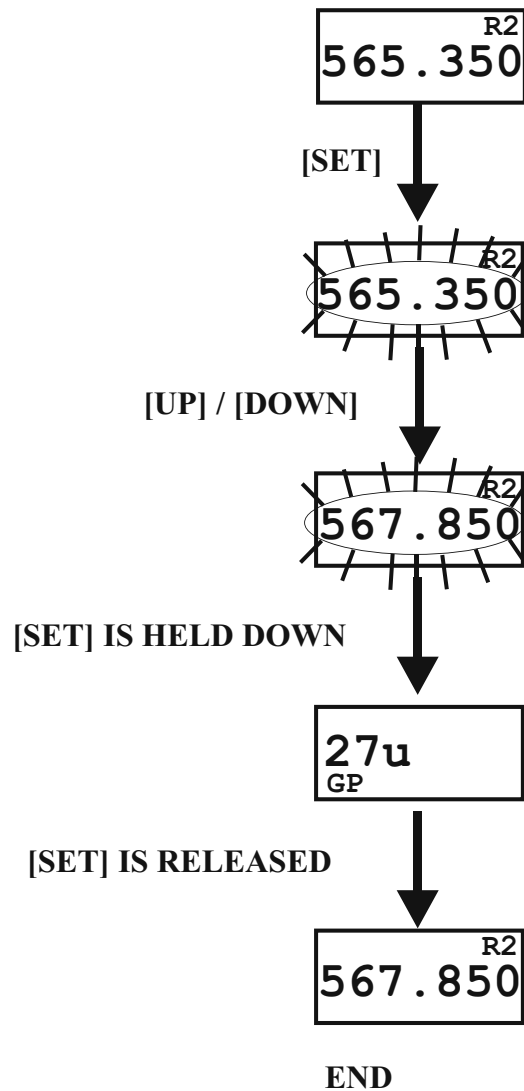


## Receive 2 Screen

The Receive 2 screen allows the user to set the beltback receive 2 frequency. This corresponds to the base station's transmit 2 frequency. In factory-defined groups receive 1 is not changeable. User-programmable groups will allow the user to change the frequency in 25 KHz steps.

- Press [MENU] three times from the group/channel screen to arrive at the receive 2 frequency screen.
- (User-Programmable Groups Only) Press [SET] to edit the frequency. The number will start flashing. Factory-defined groups can't be changed, so pressing set will do nothing at this screen. User-programmed groups will start flashing and allow the user to change the frequency in 25kHz steps.
- (User-Programmable Groups Only) Use the [UP]/[DOWN] arrow buttons to change the frequency.
- (User-Programmable Groups Only) Press [SET] to place the beltback on the frequency selected. If set is held down, during that time the group is displayed so the user is aware of what group the unit has been placed. Once set is released, the unit returns to the receive 2 frequency screen with nothing flashing.
- (User-Programmable Groups Only) Pressing [SET] once more will start the editing sequence over again. Pressing [MENU] during receive 2 frequency edit will end editing and send the user back to the receive 2 screen without any changes.

## Receive 2 Screen



## TR-800 Menu Structure

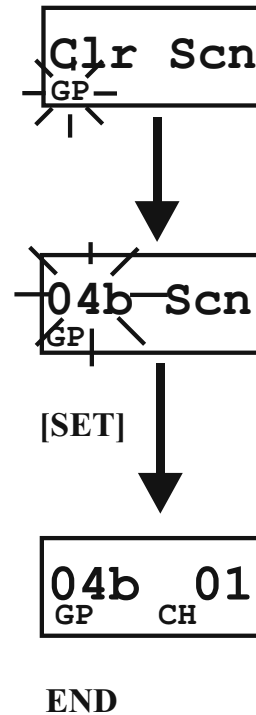
---

### ClearScan™

ClearScan™ performs a frequency scan of the factory-defined and any set-up user-programmable groups in order to find the clearest group. After about 30 seconds, the clearest group is displayed. A group is defined by receive 1 and 2 frequencies. The next best group and so forth may be accessed with the [DOWN] and [UP] arrow buttons.

- Press and hold [MENU] + [SET] for three seconds to enter ClearScan™. The beltpack will now start searching for the clearest groups. The group symbol will flash indicating the beltpack is scanning for clear groups.
- ClearScan™ will scan all groups. It will then display the 1st group it came to that had the clearest receive channels. The [UP] / [DOWN] buttons may be used to select the next best group and so forth. Hit [SET] to place the beltpack on this group and return to the group/channel screen.

### ClearScan™

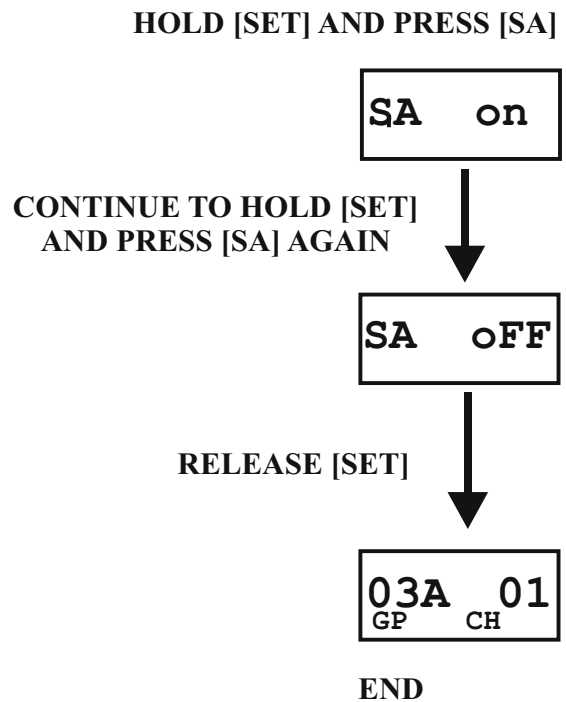


## TR-800 Menu Structure

---

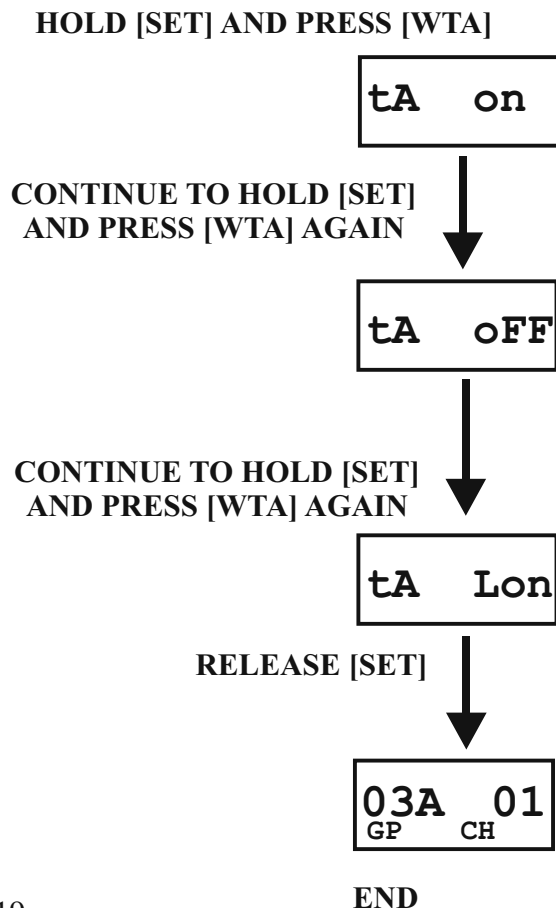
### Stage Announce Enable/Disable

- Press and hold [SET] then press the [SA] button to show the SA enable/disable screen. The current setting of the feature is displayed on the LCD.
- While continuing to hold [SET] press [SA] again to toggle the display from ON to OFF or back. Release the [SET] button to accept the current displayed setting and return to the Group/Channel screen.



### Wireless Talk Around Enable/Disable

- Press and hold [SET] then press the [WTA] button to show the WTA enable/disable screen. The current setting of the feature is displayed on the LCD.
- While continuing to hold [SET] press [WTA] again to cycle the display from on, off, then L on (latch on). Release the [SET] button to accept the current displayed setting and return to the Group/Channel screen.



## TR-800 Menu Structure

---

### Audio Channel A or B Disable/Enable

- Press and hold [SET] then press the [CHAN] button to show the channel enable/disable screen. The current setting of the feature is displayed on the LCD.
- While continuing to hold [SET], press the [CHAN] button again to move to the next option, only channel B on.
- As you continue to hold [SET], press the [CHAN] button once more to move to the next option, only channel A on. If the channel button was hit once more, the user would start over at the AB ON screen.
- Release the [SET] button to accept the current displayed setting and return to the Group/Channel screen.

### Disabling Audio Channel A

HOLD [SET] AND PRESS [CHAN]

Ab on

CONTINUE TO HOLD [SET]  
AND PRESS [CHAN] AGAIN

b on

CONTINUE TO HOLD [SET]  
AND PRESS [CHAN] AGAIN

A on

RELEASE [SET]

03A 01  
GP CH

END

---

### Talk Button Latch on/Latch off

- Press and hold [SET] then press the [TALK] button to show the Talk Button Latch/Non-Latching screen. The current setting of the feature is displayed on the LCD display.
- While continuing to hold [SET] press [TALK] again to toggle the display from on to off or back. Release the [SET] button to accept the current displayed setting and return to the Group/Channel screen.

HOLD [SET] AND PRESS [TALK]

t1 on

CONTINUE TO HOLD [SET]  
AND PRESS [TALK] AGAIN

t1 OFF

RELEASE [SET]

03A 01  
GP CH

END



# TR-800 Menu Structure

---

## Special Key Sequences

### Lockout

- Press [UP]+[DOWN] for 3 seconds to lock or unlock the beltpack. The words “Loc on” will be displayed when the feature is activated, “Loc oFF” will be displayed when the beltpack is unlocked. Pressing [MENU] will still function to view screens, but [SET] will no longer start any editing. ClearScan™, First use, Factory default and Feature enable/disable are no longer accessible.

### 1<sup>st</sup> Use Default

- Press [MENU] while turning on the beltpack to enter the 1<sup>st</sup> use default setup screen. This places the unit on group 01A with channel 01 flashing. **Any user-programmed frequencies that had been entered previously are retained.** The beltpacks must now be set to different transmit channels using the [UP]/[DOWN] buttons. Then [SET] is hit to place the units on those channels. If lockout had been activated, the beltpack comes up where it was last left regardless of [MENU] being pressed on power-up.

### Factory Default

- Pressing all four buttons [MENU]+[SET]+[UP]+[DOWN] at the same time for three seconds places the unit on group 01A with channel 01 flashing, just like beltpack 1<sup>st</sup> use default, except the **all user-programmed frequencies that had been entered previously are erased.** After the buttons are released, it still may take several seconds for the beltpack to reset. The beltpacks must now be set to different transmit channels using the [UP]/[DOWN] buttons. Then [SET] is hit to place the units on those channels. If lockout had been activated, the beltpack comes up where it was last left regardless of these four keys being pressed.

# TR-825 Menu Structure

## Beltpack Menu Structure

The following contains the main beltpack menu structure and references the pages in which further detail of that menu may be found.

All beltpack features and special key sequences can only be done from the group/channel screen.

Power-Up Screen - Pg. 7-23

S30001

c60001

Group/Channel Screen - Pg. 7-24

03A 01  
GP CH

[MENU]  
+  
[SET]

ClearScan Search Screen - Pg. 7-29

Clr Scn  
GP

[MENU]

Transmit Screen - Pg. 7-25

TX  
704.200

ClearScan Result Screen - Pg. 7-29

04A Scn  
GP

[MENU]

[MENU]  
or  
[SET]

Receive 1 Screen - Pg. 7-26

R1  
566.200

### Beltpack Feature Enable/Disable Menus:

	Page
Audio Output .....	7-28
Stage Announce (SA) .....	7-30
Wireless Talk Around (WTA) .....	7-31
Audio Channel A .....	7-32
Audio Channel B .....	7-33

[MENU]

Receive 2 Screen - Pg. 7-27

R2  
570.300

### Other Special Key Sequences:

	Page
Lockout .....	7-34
1 <sup>st</sup> Use Default .....	7-34
Factory Default .....	7-34

[MENU]

Audio Output - Pg. 7-28

Ab Add

[MENU]

**NOTE:** Pressing [MENU] within a screen after action has occurred escapes from that action and places the user at the current screen. Any editing that had been done since [SET] had been pressed is aborted.

## TR-825 Menu Structure

---

### Power-Up Screens

- The first screens displayed when the beltpack is powered up are the software and channel map version screens.
- The 1<sup>st</sup> screen displayed indicates the beltpack's software version number. It is displayed for about one second.
- The 2nd screen displayed indicates the beltpack's channel map (frequency plan) version number. It is displayed for about one second. The operating screen is then displayed.
- The final screen displayed is the group/channel screen

### Power-Up Screens

S30001



c60001



03A 01  
GP CH

END

## TR-825 Menu Structure

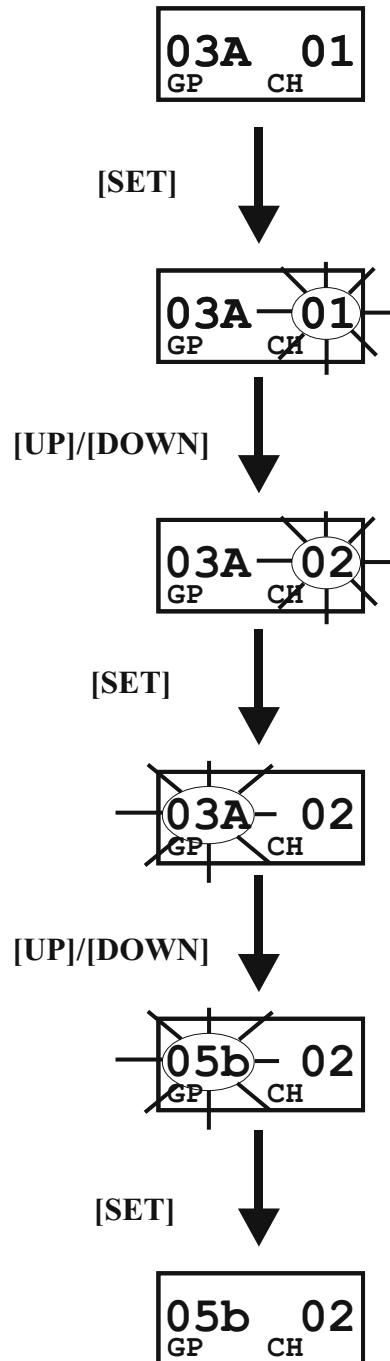
---

### Group / Channel Screen

The Group/Channel screen allows the user to change the group and select from a pre-determined number of transmit channels.

- The screen displayed after the beltpack powered-up screens.
- Press [SET] to edit the channel number. The channel number will start flashing.
- Use the [UP]/[DOWN] arrow buttons to change the channel number.
- Press [SET] to place the beltpack on the channel selected. Once set is pressed, the beltpack transmitter will move to that frequency and nothing will be flashing. Now press [SET] twice to enter group edit.
- Use the [UP]/[DOWN] arrow buttons to change the group number.
- Press [SET] to place the beltpack on the group selected. Once set is pressed, the unit returns to the group/channel display with nothing flashing.
- Pressing [SET] once more will start the editing sequence over again. Pressing [MENU] during the group edit will end editing and send the user back at the group/channel screen without any changes. This applies to channel editing also.

### Group / Channel Screen



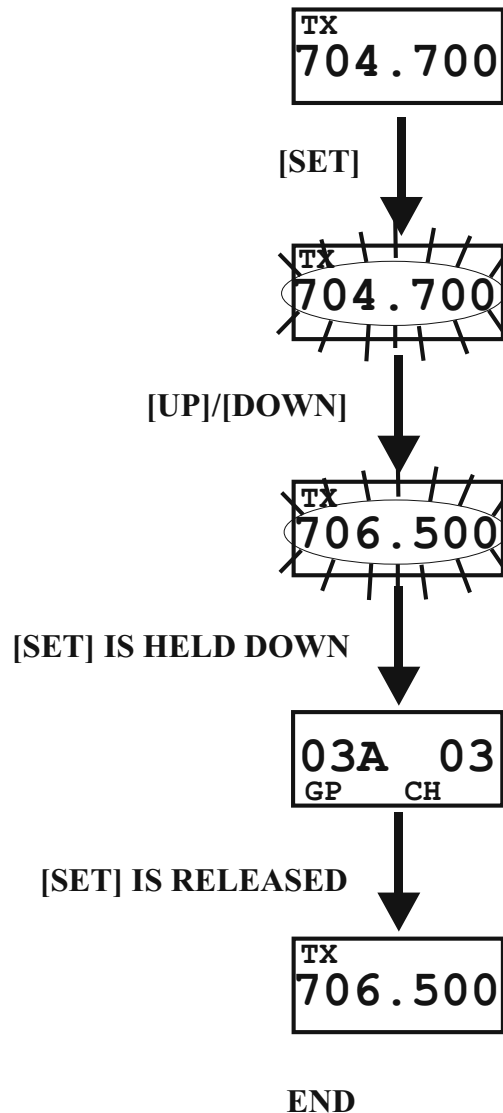
END

## Transmit Screen

The Transmit screen allows the user to set the beltpack transmit frequency. Factory-defined groups will allow only a set number of pre-defined frequencies to be selected. User-programmable groups will allow the user to change the frequency in 25kHz steps.

- Press [MENU] once from the group/channel screen to arrive at the transmit frequency screen.
- Press [SET] to edit the frequency. The number will start flashing. Factory-defined groups will allow only a set number of pre-defined frequencies to be selected. User-programmable groups will allow the user to change the frequency in 25kHz steps.
- Use the [UP]/[DOWN] arrow buttons to change the frequency.
- Press [SET] to place the beltpack on the frequency selected. If set is held down, during that time the group/channel is displayed so the user is aware of what transmit channel the unit has been placed. Once set is released, the unit returns to the transmit frequency screen with nothing flashing.
- Pressing [SET] once more will start the editing sequence over again. Pressing [MENU] during transmit frequency edit will end editing and send the user back to the transmit screen without any changes.

## Transmit Screen

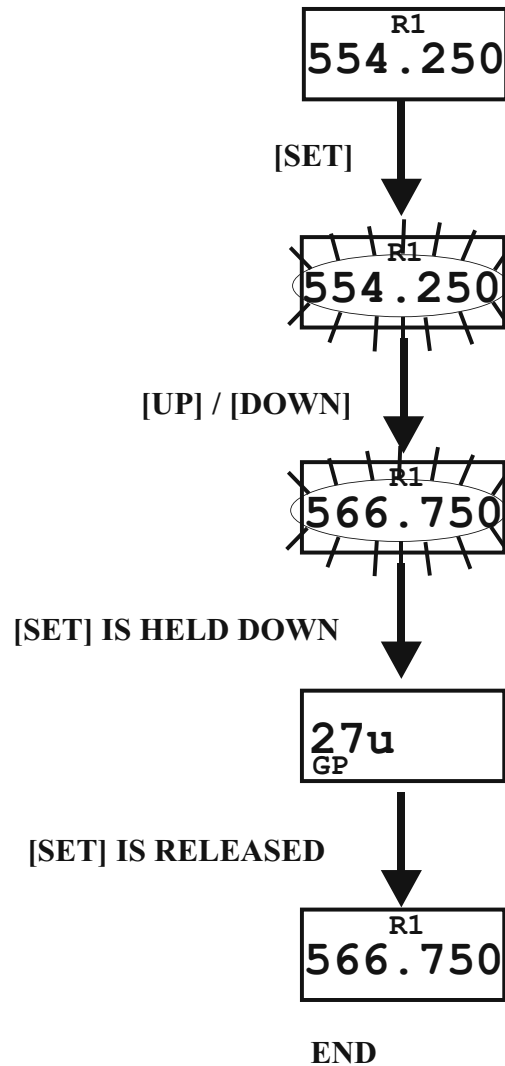


## Receive 1 Screen

The Receive 1 screen allows the user to set the beltback receiver 1 frequency. This corresponds to the base station's transmit 1 frequency. In factory-defined groups receiver 1 is not changeable. User-programmable groups will allow the user to change the frequency in 25kHz steps.

- Press [MENU] twice from the group/channel screen to arrive at the receive 1 frequency screen.
- (User-Programmable Groups Only) Press [SET] to edit the frequency. The number will start flashing. Factory-defined groups can't be changed; so pressing set will do nothing at this screen. User-programmed groups will start flashing and allow the user to change the frequency in 25kHz steps.
- (User-Programmable Groups Only) Use the [UP]/[DOWN] arrow buttons to change the frequency.
- (User-Programmable Groups Only) Press [SET] to place the beltback on the frequency selected. If set is held down, during that time the group is displayed so the user is aware of what group the unit has been placed. Once set is released, the unit returns to the receive 1 frequency screen with nothing flashing.
- (User-Programmable Groups Only) Pressing [SET] once more will start the editing sequence over again. Pressing [MENU] during receive 1 frequency edit will end editing and send the user back to the receive 1 screen without any changes.

## Receive 1 Screen

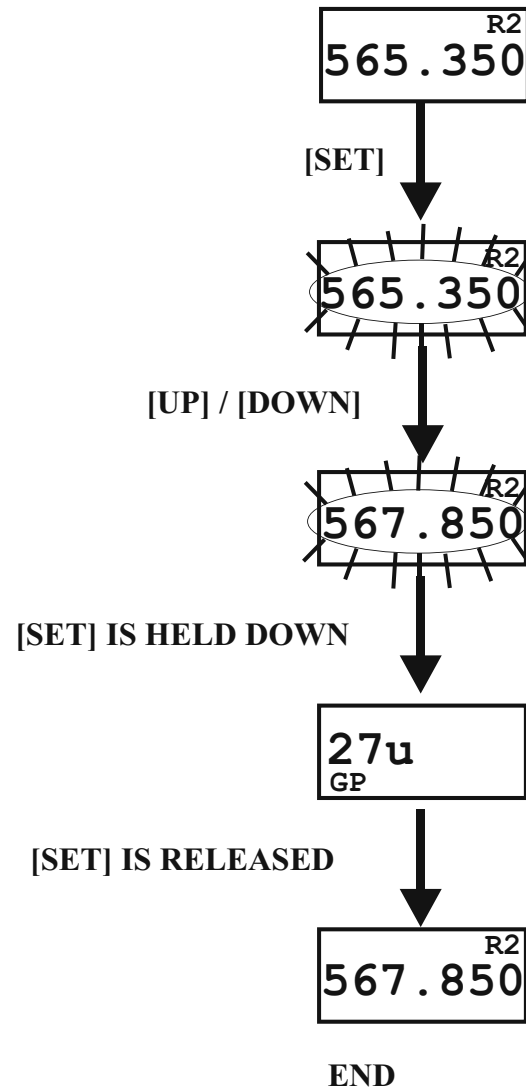


## Receive 2 Screen

The Receive 2 screen allows the user to set the beltback receive 2 frequency. This corresponds to the base station's transmit 2 frequency. In factory-defined groups receiver 2 is not changeable. User-programmable groups will allow the user to change the frequency in 25kHz steps.

- Press [MENU] three times from the group/channel screen to arrive at the receive 2 frequency screen.
- (User-Programmable Groups Only) Press [SET] to edit the frequency. The number will start flashing. Factory-defined groups can't be changed, so pressing set will do nothing at this screen. User-programmed groups will start flashing and allow the user to change the frequency in 25kHz steps.
- (User-Programmable Groups Only) Use the [UP]/[DOWN] arrow buttons to change the frequency.
- (User-Programmable Groups Only) Press [SET] to place the beltback on the frequency selected. If set is held down, during that time the group is displayed so the user is aware of what group the unit has been placed. Once set is released, the unit returns to the receive 2 frequency screen with nothing flashing.
- (User-Programmable Groups Only) Pressing [SET] once more will start the editing sequence over again. Pressing [MENU] during receive 2 frequency edit will end editing and send the user back to the receive 2 screen without any changes.

## Receive 2 Screen



## TR-825 Menu Structure

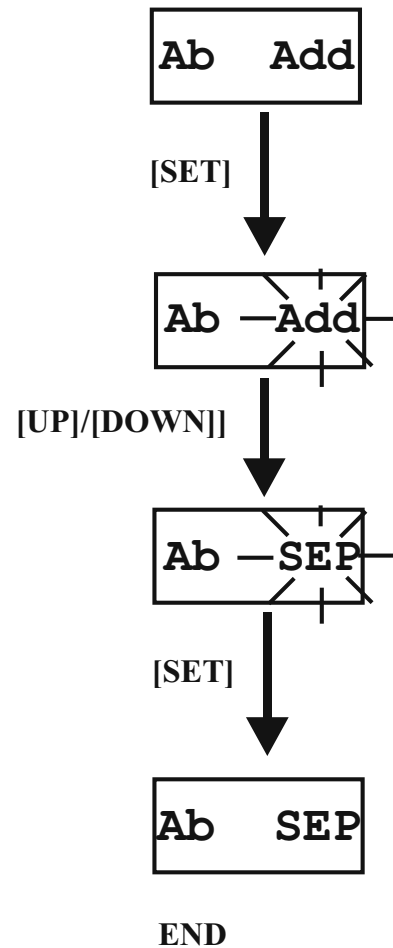
---

### Audio Output

The Audio Output screen allows the user to set the audio output to Mono (Add) or Stereo (SEP). This option only applies to beltpacks with 5 pin headset connectors. Single sided 5-pin headsets will only receive A or B Audio depending on how the headset is wired. Single sided 5-pin headsets must set the audio output to "Ab SEP". The audio output option setting does nothing with a 4 pin headset connector.

- Press [MENU] four times from the group/channel screen to arrive at the audio output screen
- Press [SET] to change the setting. The option will start to flash.
- Use the [UP]/[DOWN] arrow buttons to change the audio output option.
- Press [SET] to end editing and accept the setting.

### Audio Output





## TR-825 Menu Structure

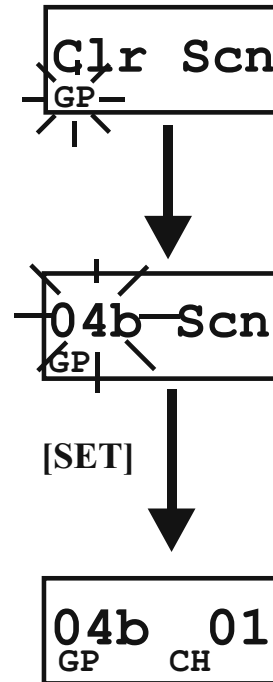
---

### ClearScan™

ClearScan™ performs a frequency scan of the factory-defined and any set-up user-programmable groups in order to find the clearest group. After about 30 seconds, the clearest group is displayed. A group is defined by receive 1 and 2 frequencies. The next best group and so forth may be accessed with the [DOWN] and [UP] arrow buttons.

- Press and hold [MENU] + [SET] for three seconds to enter ClearScan™. The beltpack will now start searching for the clearest groups. The group symbol will flash indicating the beltpack is scanning for clear groups.
- ClearScan™ will scan all groups. It will then display the 1st group it came to that had the clearest receive channels (lowest RSSI levels on the two frequencies). The [UP] / [DOWN] buttons may be used to select the next best group and so forth. Press [SET] to place the beltpack on this group and return to the group/channel screen.

### ClearScan™



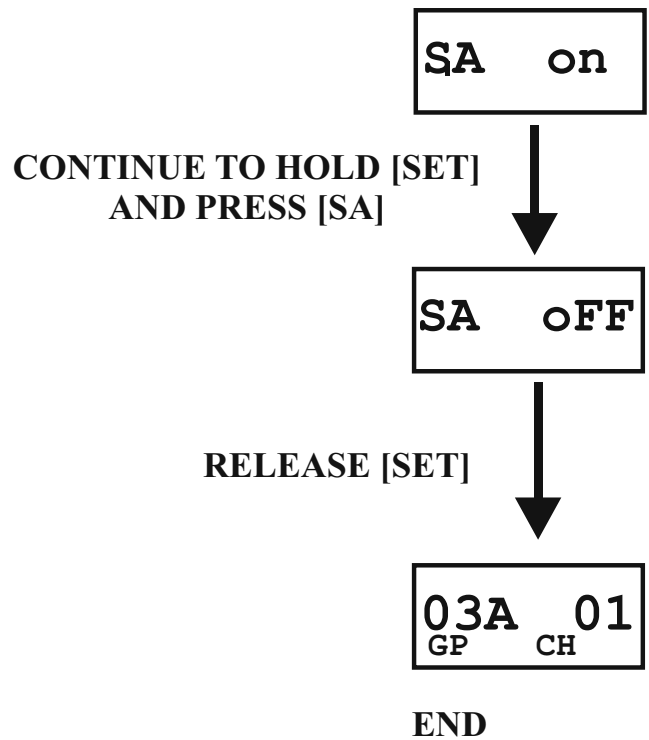
END

## TR-825 Menu Structure

---

### Stage Announce Enable/Disable

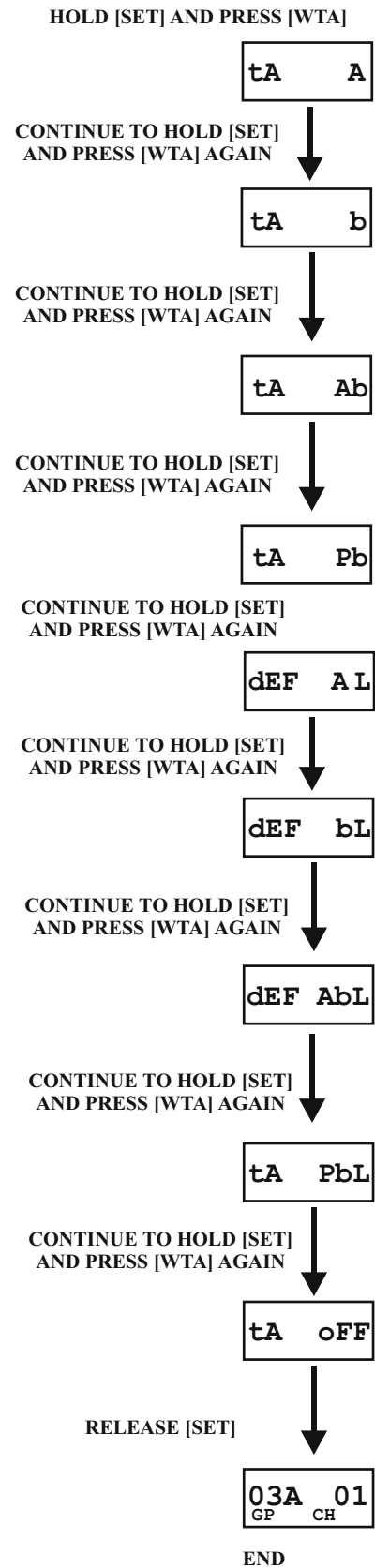
- Press and hold [SET] then press the [SA] button to show the SA enable/disable screen. The current setting of the feature is displayed on the LCD display.
- While continuing to hold [SET] press [SA] again to toggle the display from ON to OFF or back. Release the [SET] button to accept the current displayed setting and return to the Group/Channel screen.
- *NOTE: When SA is enabled and pressed, whatever is on; A talk, B talk, or both, goes out. No audio channels show active when SA is pressed.*



# TR-825 Menu Structure

## Wireless Talk Around

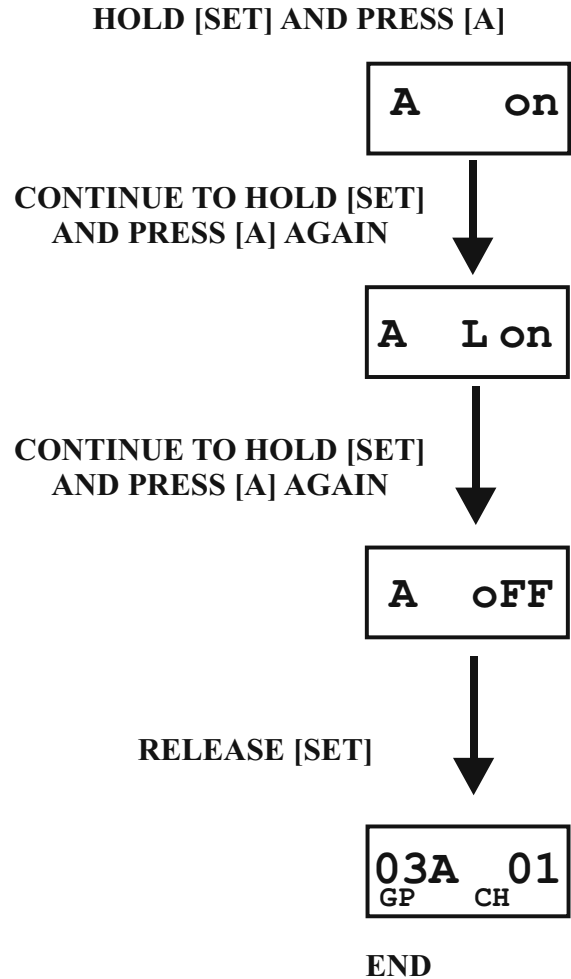
- Press and hold [SET] then press the [WTA] button to show the WTA menu screen. The current setting of the feature is displayed on the LCD display. The first screen to the right is currently set to a default of “A” channel, nonlatching.
- While continuing to hold [SET] press [WTA] again to go to the next selection; Talk Around = “B” channel, non-latching.
- Talk Around = “A” + “B” channels, non-latching.
- Talk Around = “Push-Button”, non-latching. Whatever talk button is active becomes wireless talk around.
- Talk Around = “A” channel, latching.
- Talk Around = “B” channel, latching.
- “A” + “B” channels, latching.
- Talk Around = “Push-Button”, latching. Whatever talk button is active becomes wireless talk around.
- While continuing to hold [SET], press [SA] once again to display the final menu option “Talk Around = Off”. Release the [SET] button on any of the above screens to accept the current displayed setting and return to the Group/Channel screen.



## Audio Channel A Options

- Press and hold [SET] then hit the [A] button to show the channel “A” menu screen. The current setting of the button is displayed on the LCD display; Channel “A” “Talk-Latching Off”.
- While continuing to hold [SET], press the [A] button again to move to the next option; Channel “A” Talk - Latching On.
- As you continue to hold [SET], press the [A] button once more to move to the next option, Channel “A” Off.
- Release the [SET] button to accept the current displayed setting and return to the Group/Channel screen.

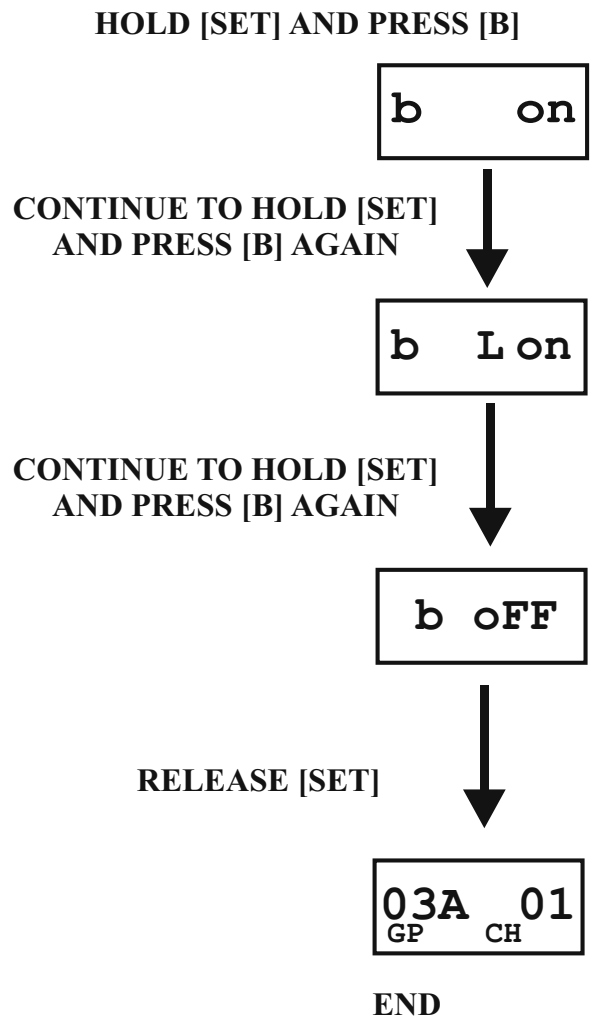
## Audio Channel A Options



## Audio Channel B Options

- Press and hold [SET] then hit the [B] button to show the channel “B” menu screen. The current setting of the button is displayed on the LCD display; Channel “B” Talk-Latching Off.
- While continuing to hold [SET], press the [B] button again to move to the next option; Channel “B” Talk-Latching On.
- As you continue to hold [SET], press the [B] button once more to move to the next option, Channel “B” Off.
- Release the [SET] button to accept the current displayed setting and return to the Group/Channel screen.

## Audio Channel B Options



## TR-825 Menu Structure

---

### Special Key Sequences

#### Lockout

- Press [UP]+[DOWN] for 3 seconds to lock or unlock the beltpack. The words “Loc on” will be displayed when the feature is activated, “Loc oFF” will be displayed when the beltpack is unlocked. Pressing [MENU] will still function to view screens, but [SET] will no longer start any editing. ClearScan™, First use, Factory default, and Feature enable/disable are no longer accessible. The words “Loc out” will be flashed on the screen if any editing is attempted during lockout.

#### 1<sup>st</sup> Use Default

- Press [MENU] while turning on the beltpack to enter the 1<sup>st</sup> use default setup screen. This places the unit on group 01A with channel 01 flashing. **Any user-programmed frequencies that had been entered previously are retained.** The beltpacks must now be set to different transmit channels using the [UP]/[DOWN] buttons. Then [SET] is hit to place the units on those channels. If lockout had been activated, the beltpack comes up where it was last left regardless of [MENU] being pressed on power-up.

#### Factory Default

- Pressing all four buttons [MENU]+[SET]+[UP]+[DOWN] at the same time places the unit on group 01A with channel 01 flashing, just like beltpack 1<sup>st</sup> use default, except the **all user-programmed frequencies that had been entered previously are erased.** The beltpacks must now be set to different transmit channels using the [UP]/[DOWN] buttons. Then [SET] is pressed to place the units on those channels. If lockout had been activated, the beltpack comes up where it was last left regardless of these four keys being pressed.

# Section 8

## System Walk-Thru

---

Now that you have successfully “set-up” your Telex Wireless Intercom System and turned on any auxiliary equipment, you are ready to test the overall performance by “Walking” the Telex system through the areas in which you will be using it.

Before you begin your walk-thru, check the following:

- Beltpack Battery Check.
- Set microphone gain in both the beltpack(s) and the base station.
- The base station and beltpack(s) are on the same group and the beltpack(s) are on their own unique transport channels that match the base station receive channels
- Check that the talk button is engaged. The talk LED will be illuminated.
- Intercom Level “IN” and “OUT” are set to an appropriate level.
- Auxiliary Level “IN” and “OUT” are set to an appropriate level (if used).

The “system walk-thru” can detect problem of weak signal strength caused by:

- Poor antenna location
- Wrong antenna for receiver and/ or transmitter
- RF “Trouble Spots”
- Operating distance beyond system capability.
- Old or used batteries in the TR-8XX.

Under normal conditions the base station’s display will indicate a beltpack status. “Weak Signal” condition will result in “no tx” being displayed on the base station’s receiver for that beltpack.

In 99% of all instances you will set up your Telex Wireless Intercom System, walk it through the area of interest and achieve error-free performance. If in the rare instance your Telex system does not “pass” during your walk-thru evaluation, refer to the section of this manual which deals with System Troubleshooting.





# Section 9

## Troubleshooting

Reread the sections of this manual to make sure you have completed system set-up properly.

If you are unable to solve the problem, contact the dealer from whom you purchased the system for assistance.

PROBLEM	SOLUTION
<b>DISTORTION</b> - System's audio quality seems distorted at medium to high input levels.	Reduce microphone gain by adjusting microphone gain control.
<b>HISS</b> - System seems to produce a "hiss" which is undesirable.	Check the gain setting on all beltacks and the base. They may be too low or too high. Check to make sure you are still well within range of the base station.
<b>LOW OUTPUT</b> - System produces a low output level.	Check the gain setting on both the beltacks and the base. They may be too low.
<b>FEEDBACK</b> - Moving around area of use produces "squeal" or "howl" in various locations using ext. speakers.	Reduce the gain settings on both the beltacks and the base. They may be too high.
<b>DROPOUTS</b> - When moving around the area of use there seems to be locations where the signal "swooshes" or completely disappears.	Make sure both antennas on the base and beltack are connected and follow the location suggestions. Change the location of the base unit and antennas or avoid the bad areas with the remote beltacks.
<b>INTERFERENCE</b> - System picks up signals other than wireless intercoms.	Make sure that all the Telex beltack(s) are on. If there are any unused receivers at the base, turn the audio off from those receivers by deselecting the appropriate "Portable Station Connect" button.  If problems persist with the beltack on, you will probably need to change the group. Make sure the base and beltack match after any Group/Channel change.
<b>NO AUDIO</b> from BASE or BELTPACK headsets.	Check Transmitter switch on base and beltack. Check talk LED to make sure is on. Make sure beltack batteries are OK.

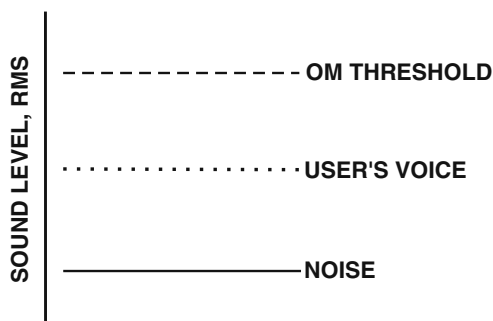


## Frequency Interaction

Unfortunately, radio frequency (RF) channels cannot be randomly selected for use in radio devices. They must be selected to avoid known frequencies in use, FCC restrictions on the location of devices, and even interference between your own RF devices. The factory defined frequencies (Groups 01A-24) selected by Telex for this RadioCom™ system are chosen to minimize possible interference.

## Microphone Gain Adjustment

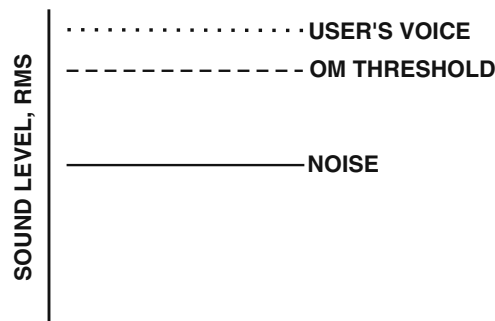
The microphone gain controls on the base station and beltpack are set to mid-levels by the factory. In most cases this setting will work fine and only on loud speech will the overmodulation (OM) indicator light. However, in environments where the background noise is loud or the user has a strong/quiet voice, the gain control will need to be adjusted. In Figure 33 the gain is set correctly. The user's root-mean-square (RMS) sound level is well below the OM threshold and only on peaks does his or her voice flash the OM indicator light.



**Figure 33**  
**Low Noise Environment**  
**Microphone Gain Set Correctly**

Figure 34 displays the same gain setting as in Figure 33 but brought into a high noise environment. The user's voice now lights the OM indicator all the time he or she speaks due to the higher noise plus the user speaking louder. The result on the system is distortion on louder speech. The microphone gain must be reduced. The same applies to a user with a powerful voice. If someone sets the system mic gain to their voice and user has a much stronger voice, then the gain will need to be reduced, even if the background noise is the same.

Always remember to set the microphone gain based on the situation and location in which the equipment will be used. If the equipment is used on the field during a football game, set the gain based upon a loud stadium, NOT the quiet stadium 2 hours before a game. If a production studio user has a quiet voice, set the gain to their voice and NOT the stage hand's loud voice who helped set up the system.



**Figure 34**  
**High Noise Environment**  
**Microphone Gain Set Too High**



# Section 11

## Battery Information

Improper battery selection, use, installation and care are the cause of numerous wireless system failures.

**Alkaline Batteries:** Alkaline batteries such as Mallory's DURACELL® or Eveready's ENERGIZER® provide the most reliable operation in wireless transceivers.

**The use of low cost carbon-zinc batteries is NOT recommended.**

**Nickel-Metal Hydride Batteries:** These batteries can save you money in the long run, as they can be recharged. Typical battery life is about 70-80% of the length of time alkaline batteries last.

### **Battery Life:**

#### **TR-800**

Alkaline, 12-14 Hours

Nickel Metal Hydride, 9-11 Hours

#### **TR-825**

Alkaline, 9-11 Hours

Nickel Metal Hydride, 7-9 Hours

### **WARNING:**

Do not place an alkaline TR-8XX battery pack in any battery charger. Severe charger and battery pack damage may result.

Energizer® is a registered trademark of Union Carbide Corporation.  
Duracell® is a registered trademark of Duracell Inc.

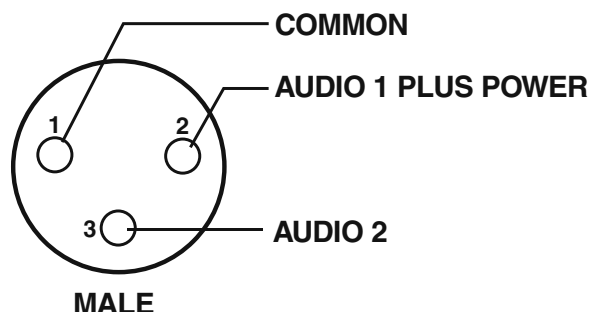


# Section 12

## Intercom Systems Specifications

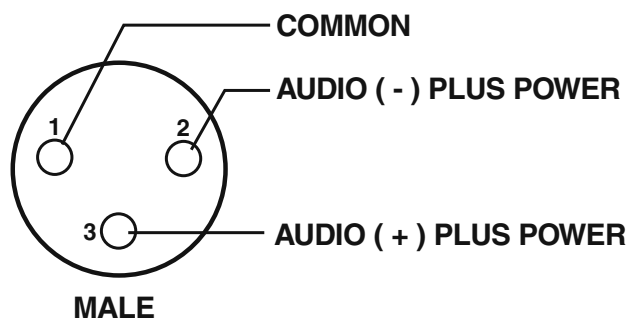
### RTS

Input Impedance:.....200Ω  
 Output Level:.....0.775 Vrms nominal  
 Bridging Impedance:.....>10kΩ  
 Call Signaling:  
   Send: .....20kHz ±100 Hz, 240 mVrms  
   Receive: .....20kHz ±800 Hz, 100 mVrms  
 Power Voltage: .....28.0 VDC nominal



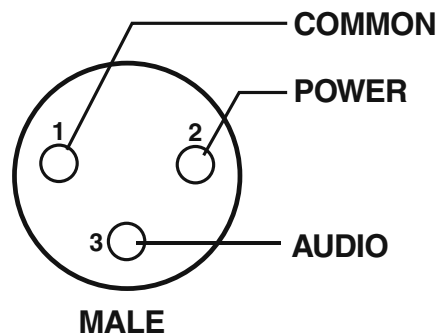
### AudioCom/Telex

Input Impedance:.....300Ω  
 Output Level:.....1.0 Vrms nominal  
 Bridging Impedance:.....>10kΩ  
 Call Signaling:  
   Send: .....20kHz 100 Hz, 05 mVrms  
   Receive: .....20kHz 800 Hz, 100 mVrms  
 Power Voltage: .....24.0 VDC nominal



### Clear-Com

Input Impedance:.....200Ω  
 Output Level:.....1.0 Vrms nominal  
 Bridging Impedance:.....>10kΩ  
 Call Signaling:  
   Send: .....12 3 VDC  
   Receive: .....4 VDC Minimum  
 Power Voltage: .....30.0 VDC nominal







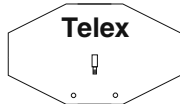
# Section 13

## Accessories and Replacement Parts

### ALP-600

450-900 MHz Bi-Directional Log Periodic Antenna Includes mounting hardware and 10 feet (3 meters) of coaxial cable with TNC Connectors

P N. 878896



### ALP-450

450-900 MHz Log Periodic Antenna Includes mounting hardware and 10 feet (3 meters) coaxial cable with TNC connectors

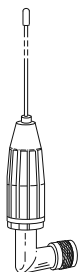


Order No. 71147000

### Antenna Cables

Special low loss antenna cables with TNC Connectors

Model No.	Length	Order No.
CXU-10	10 Ft. (3 meter)	690419
CXU-25	25 Ft. (7.6 meter)	71151-025
CXU-50	50 Ft. (15 meter)	71151-050
CXU-75	75 Ft. (23 meter)	71151-075
CXU-100	100 Ft. (30 meter)	71151-100

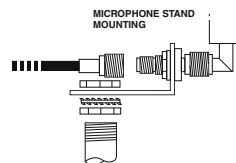


1/2-Wave Ground Plane Independent Antenna

### Base Station's 1/2 - Wave Antennas

Model No.	Part No.	Band Color	Frequency	C6	A2	B4	E88
CLA-1	870658-1	Blue	520-564.9 MHz			Tx	
CLA-2	870658-2	Yellow	565-614.9 MHz				Tx
CLA-3	870658-3	Red	615-659.9 MHz		Rx		
CLA-4	870658-4	White	660-689.9 MHz			Rx	
CLA-5	870658-5	Green	690-724.9 MHz	Rx			
CLA-6	870658-6	Orange	725-760 MHz				
CLA-8	870658-8	Purple	796-865 MHz				
CLA-10	870658-10	Tan	470-506 MHz				Rx
CLA-11	870658-11	Pink	515-548 MHz		Tx		
CLA-12	870658-12	Brown	542-575 MHz	Tx			

### AB-2



Bracket for 1/2 wave Antenna with 10 ft. of coax-

PN 71138000

### BTR Power Cords

North America .....	550024013
U.K. ....	550024002
European .....	550024000
Australian .....	550024018

### BTR Intercom Dummy Load

Telex type.....	PN 878935
RTS type.....	PN 878990

SA Relay screw plug adapter .....PN 2862046

TR LCD/switch cover.....PN 450364

### BP-700 TR Battery pack, alkaline

(batteries not included).....PN 71315-000

### BP-700NM TR Nickel Metal Hydride

Battery pack .....PN 71315-001

### BC-700NM4

U.S./Canada .....71315400

### Four Slot "Smart" Charger

Euro .....71315401

with Four Nickel Metal

U.K. ....71315402

Hydride Battery Packs

### BC-700NM

U.S./Canada .....71315100

### Single Slot "Smart" Charger

Euro .....71315101

with Nickel Metal Hydride

Battery Pack

U.K. ....71315102

### Beltpack's 1/4-wave antenna

Part No.	Color Dot	Frequency	C6	A2	B4	E88
879220-2	Black	485.0-553.9 MHz		Rx	Rx	
879220-3	Yellow	554.0-635.9 MHz	Rx			Rx
879220-4	Green	636.0-725.9 MHz	Tx	Tx	Tx	
879220-1	Violet	425.0-488.0 MHz				Tx
879220-5	Red	726.0-826.0 MHz				
879220-6	Blue	826.0-930.0 MHz				



**Customer Service Information**

If your receiver or transmitter should need servicing, please contact:

Customer Service Department  
TELEX COMMUNICATIONS, INC.  
8601 East Cornhusker Highway,  
Lincoln, Nebraska 68507-9702 U.S.A.  
Phone: (402) 467-5321 or 1-800-553-5992

All claims of defect or shortage should be sent to the above address. When returning items for service, you must provide date and proof of purchase, such as a copy of the sales receipt, to establish warranty. A letter should be included outlining all symptoms and claimed defects. Information on how the equipment was installed and used is very helpful. Please include your phone number and return address in case our service technicians need to contact you.

Units that have been modified cannot be accepted for repair.

Include all information requested by the Service Department. Then pack the unit as follows:

Check the unit to see that all parts and screws are in place. Then wrap it in heavy paper or put it in a plastic bag. If the original carton is not available, place the unit in a strong carton that is at least six inches bigger in all three dimensions than the unit. Fill the carton equally around the unit with resilient packing material (shredded paper, foam, etc.). Seal it with gummed paper tape, tie it with a strong cord, and ship it by prepaid express, United Parcel Service or insured parcel post to the Telex Service Department.

It is very important that the shipment be well-packed and fully insured. Damage claims must be settled between you and the carrier and this can delay repair and return of the unit to you.

Telex reserves the right to make changes in design and improvement on its product without assuming any obligation to install the same on any of its products previously manufactured. Further Telex reserves the right to ship new and/or improved products which are similar to the form, fit and function of products originally ordered.



# Section 15

## Software License

### End-User License Agreement for Telex® Software

**IMPORTANT** - Please read this document carefully before using this product.

THIS DOCUMENT STATES THE TERMS AND CONDITIONS UPON WHICH TELEX COMMUNICATIONS, INC. (the "COMPANY") OFFERS TO LICENSE THE INSTALLED SOFTWARE OR PROGRAM (the "SOFTWARE") FOR USE WITH THE PRODUCT IN WHICH IT WAS INSTALLED. YOU ARE AGREEING TO BECOME BOUND BY THE TERMS OF THIS AGREEMENT. IF YOU DO NOT AGREE TO THE TERMS OF THIS AGREEMENT, DO NOT USE THIS PRODUCT. PROMPTLY RETURN THE PRODUCT TO THE PLACE WHERE YOU OBTAINED IT FOR A FULL REFUND.

The installed software as supplied by the Company is licensed, not sold, to you for use only under the terms of this license, and the Company reserves all rights not expressly granted to you. You own the product or other media on or in which the Software is originally or subsequently recorded or fixed, but the Company retains ownership of all copies of the Software itself.

1. License: This license allows you to use the Software for internal purposes only on a single product in which it was installed.
2. Restrictions: (a) You may not market, distribute or transfer copies of the Software to others or electronically transfer or duplicate the software. YOU MAY NOT REVERSE ENGINEER, DECOMPILE, DISASSEMBLE, MODIFY, ADAPT, TRANSLATE, RENT, LEASE OR LOAN THE SOFTWARE OR CREATE DERIVATIVE WORKS BASED ON THE SOFTWARE OR ANY ACCOMPANYING WRITTEN MATERIALS. (b) The Software and the accompanying written materials are copyrighted. Unauthorized copying of the Software, including portions thereof or the written materials, is expressly forbidden. (c) You understand that the Company may update or revise the Software and in so doing incurs no obligation to furnish such updates to you.
3. Limited Warranty: The company does not warrant that the operation of the Software will meet your requirements or operate free from error. The company DISCLAIMS ALL OTHER WARRANTIES AND CONDITIONS EITHER EXPRESS OR IMPLIED, INCLUDING THE WARRANTIES OF MERCHANTABILITY, FITNESS FOR A PARTICULAR PURPOSE AND NON-INFRINGEMENT OR THIRD PARTY RIGHTS.
4. Limited Liability: The liability of the company for any claims arising out of this License based upon the Software, regardless of the form of action, shall not exceed the greater of the license fee for the Software or \$50.



### FCC LICENSING

The Telex BTR-800, TR-800, and the TR-825 Transmitter/Receiver are Type Accepted under United States Federal Communications Commission Part 74. Licensing of Telex equipment is the User's responsibility and licensibility depends on the user's classification, users application, and frequency selected. Telex strongly urges the user to contact the appropriate telecommunications authority for any desired clarification.

**CAUTION:** Changes or modifications made by the user could void the user's authority to operate the equipment.

### Mandatory Safety Instructions to Base Station Installers and Users

1. Use only manufacturer or dealer supplied antenna. Antenna minimum safe distance, as calculated from FCC requirements, is 4.8cm. However, the FCC default for the minimum safe distance is 20cm. Antenna gain: zero dBd referenced to a dipole.
2. The FEDERAL COMMUNICATIONS COMMISSION has adopted a safety standard for human exposure to RF (Radio Frequency) energy, which is below the OSHA (Occupational Safety and Health Act) limits.
3. To comply with current FCC RF Exposure limits, the antenna must be installed at or exceeding the minimum safe distance show here, and in accordance with the requirements of the antenna manufacturer or supplier.
4. Antenna substitution: Do Not substitute any antenna for the one supplied by or recommended by the manufacturer or radio dealer. You may be exposing person or persons to harmful radio frequency radiation. You may contact your radio dealer or the manufacturer for further instructions.
5. **WARNING:** Maintain a separation distance from the antenna to person(s) of at least 20cm.

You, as the qualified end-user of this radio device must control the exposure conditions of bystanders to ensure that the minimum separation distance (above) is maintained between the antenna and nearby persons for satisfying RF Exposure compliance.

The operation of this transmitter must satisfy the requirements of the General Population/Uncontrolled Exposure Environment for work-related use. Transmit only when person(s) are at least the minimum distance from the properly installed, externally mounted antenna.





# Section 17

## Limited Warranty

### Limited Warranty (Valid United States and Canada Only)

TELEX Communications, Inc. ("Telex") warrants to the user, who originally purchased the serialized product delivered with this card, that the product will be free from defects in material and workmanship for the following periods after such date of purchase. Material 36 months, workmanship 36 months. Microphones, earphones, neckloops, cables & connectors are warranted for ninety days. Telex will, at its option, repair or replace free of charge such defective products subject to the following conditions:

1. Delivery of the product or parts postage prepaid to the Telex dealer, authorized service facility or factory.
2. Determination by Telex that a defect exists and is covered by limited warranty. Defects due to alteration, repair by unauthorized persons, insertion of non-Telex parts, misuse, accidental damage, use of the equipment for purposes other than those for which it was designed, and the like, are not covered by this limited warranty and repairs thereof will be subject to normal service charges.
3. Repairs and replacement parts are covered under this limited warranty only for the unexpired term of the original limited warranty.
4. Products purchased from unauthorized dealers are not warranted.
5. You must fill out and return the product warranty card to register the purchase date of serialized items. A copy of the bill of sale showing the date of purchase must accompany all warranty work.

THIS LIMITED WARRANTY IS EXPRESSLY IN LIEU OF ANY EXPRESS OR IMPLIED WARRANTY, INCLUDING ANY IMPLIED WARRANTY OR MERCHANTABILITY OR FITNESS FOR A PARTICULAR PURPOSE WHICH EXTENDS BEYOND THE TERM HEREOF. THE REMEDIES PROVIDED BY THIS LIMITED WARRANTY ARE THE ONLY REMEDIES AVAILABLE TO ANY PERSON. NO PERSON HAS ANY AUTHORITY TO BIND TELEX TO ANY REPRESENTATION OR WARRANTY OTHER THAN THOSE PROVIDED BY THIS LIMITED WARRANTY. TELEX SHALL NOT BE LIABLE FOR ANY INCIDENTAL OR CONSEQUENTIAL DAMAGES CAUSED BY FAILURE OR OTHERWISE OF THE PRODUCT.

Some states do not allow exclusions or limitations of incidental or consequential damages or limitations on how long an implied warranty lasts, so the limitations or exclusions herein may not apply to you. This warranty gives you specific legal rights, and you may also have other rights which vary from state to state.



**TELEX**<sup>®</sup>

---

TELEX COMMUNICATIONS, INC. • 12000 Portland Ave. South, Burnsville, MN 55337.  
PN 803257-1 Rev. E

MAY 2003

Made in U.S.A.